

120 GALLON DOUBLE WALL TANK 29.0 X 34.0 X 37.5

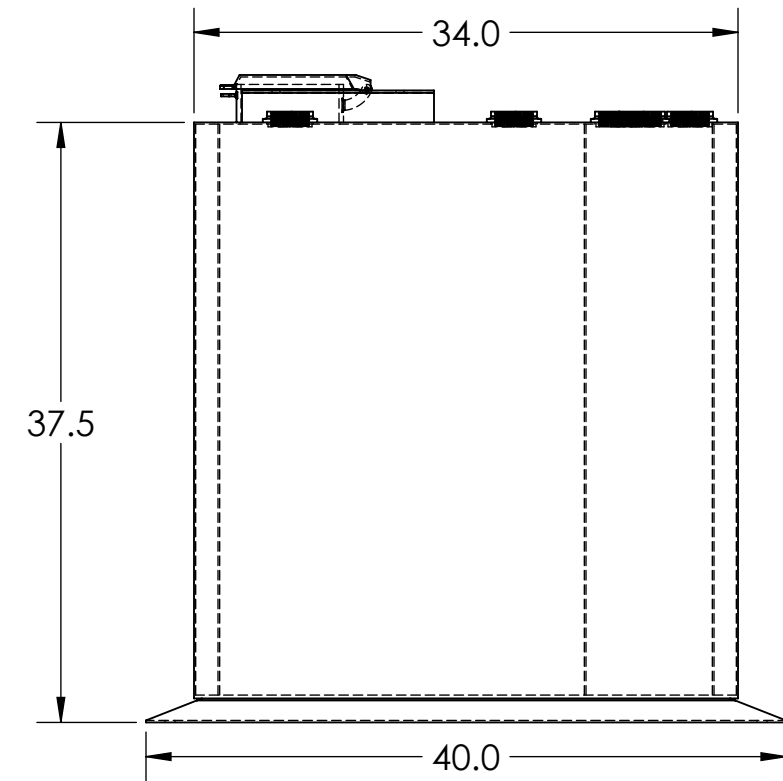
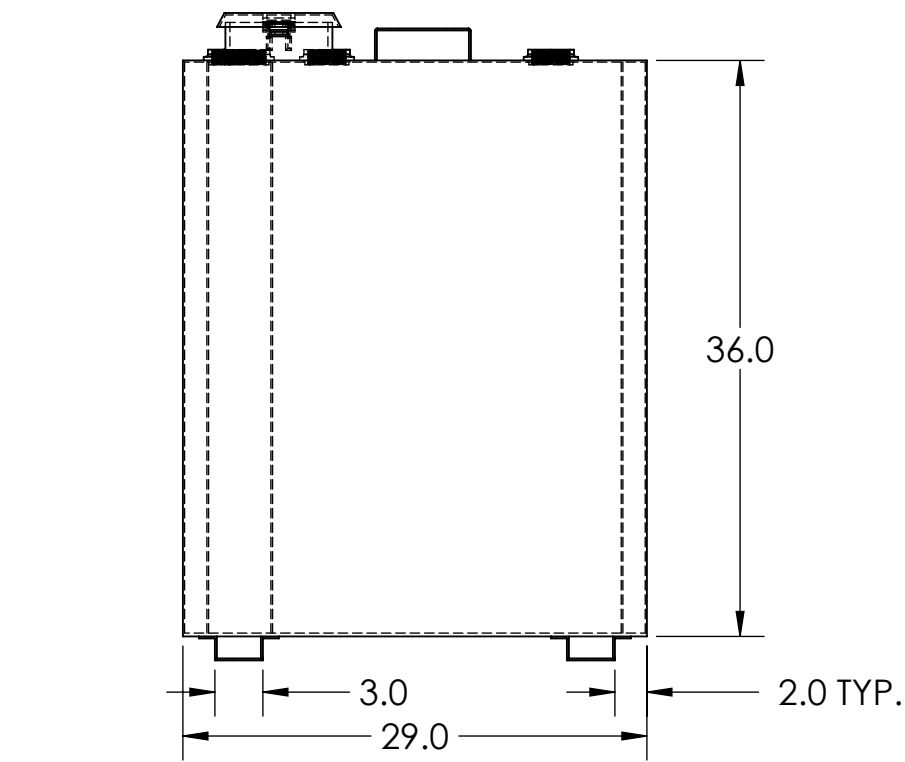
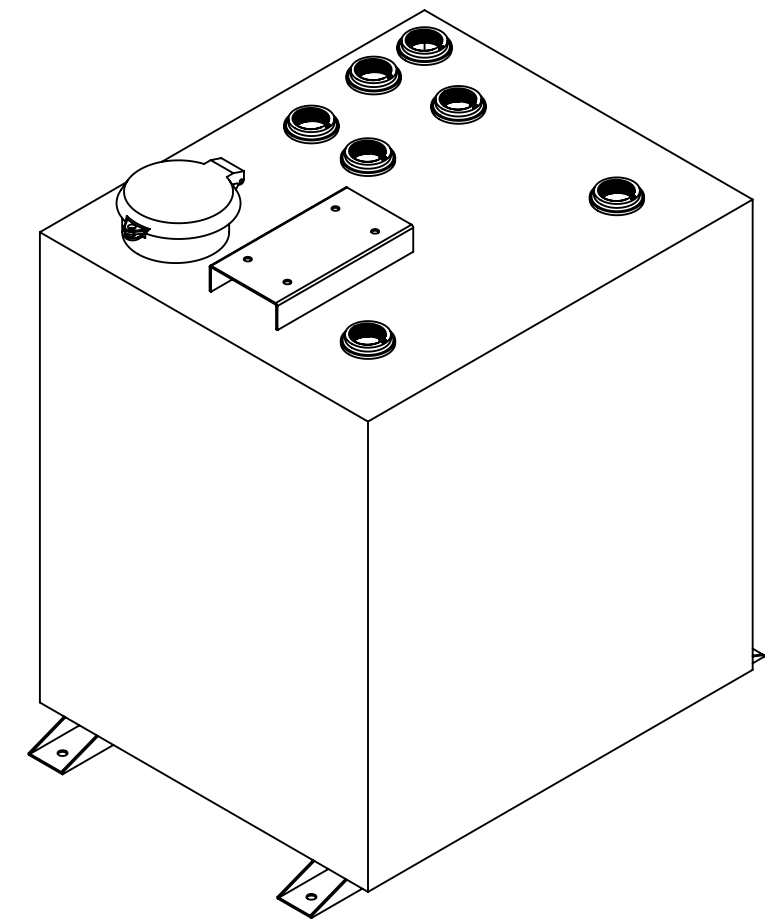
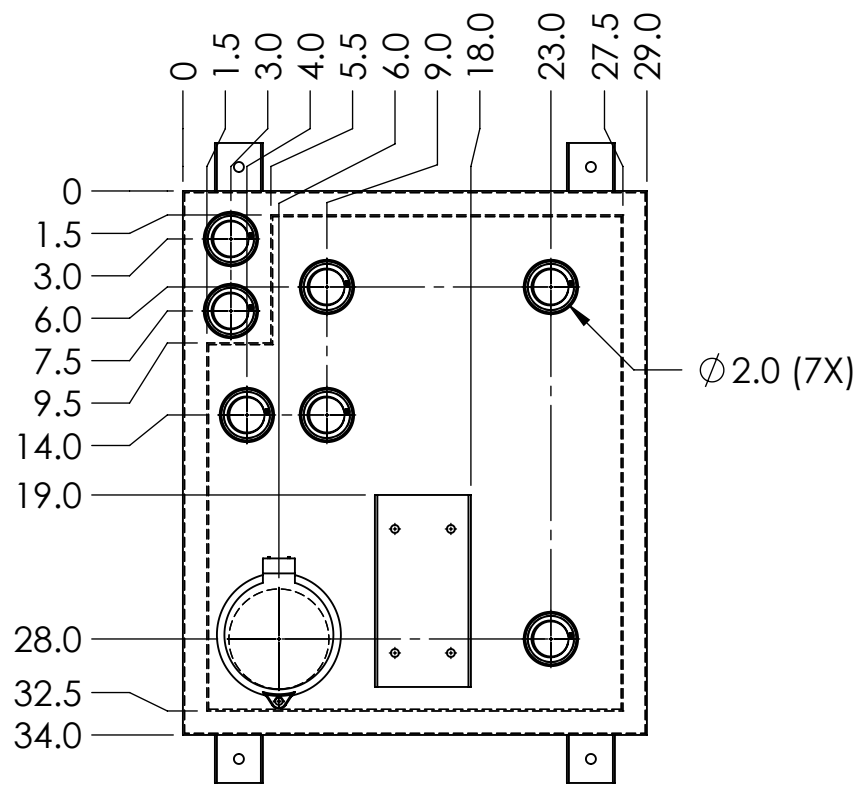

- (1) 6" Hatch in Primary
- (5) 2" FNPT in Primary
- (2) 2" FNPT in Secondary
- (1) 6"x12" Reel BKT
- (2) Extended Tank Support
- Powder Coat Finish
- 1 Year Warranty on Material and Workmanship
- *No provision for Lost Product or Business

PROPRIETARY AND CONFIDENTIAL
THE INFORMATION CONTAINED IN THIS DRAWING IS THE SOLE PROPERTY OF SUPERIOR STORAGE TANKS. ANY REPRODUCTION IN PART OR AS A WHOLE WITHOUT THE WRITTEN PERMISSION OF SUPERIOR STORAGE TANKS IS PROHIBITED.

AMERICAN
LUBRICATION EQUIPMENT CORPORATION®
11212A McCormick Road
Hunt Valley, MD 21031

GALLON	117	MATERIAL	12Ga	SIZE	B	120 GALLON DOUBLE WALL TANK	
Label		C.S. A36					
UL-142 SECONDARY CONTAINMENT		UL-142, FILE#	MH14783	DATE	11/17/2020	120BDW	WEIGHT:
						lbs.	SCALE: 1:12 SHEET 1 OF 1