

## PUMP LIFT, AIR OPERATED

For use on bung type pumps (400 lb. size drum)



### READ THIS MANUAL CAREFULLY BEFORE INSTALLING, OPERATING OR SERVICING THIS EQUIPMENT.

It is the responsibility of the employer to place this information in the hands of the operator. Keep for future reference.

NOTE: Lift height when extended = 92".  
Lift height when retracted = 55-1/2".

### ASSEMBLY

1. With drum of lubricant and pump in desired location, determine proper position for lift.
2. Drill holes in floor for base; see views for dimensions.
3. Secure base to floor and install air valve to base.

4. With cover on drum, and with lift in down position, secure the clamp 60209 in position on lift so that it rests on drum cover. Hook "J" bolts under cover and secure cover to clamp by tightening Y12-5 nuts. Assembly top support brackets 73395 on ends of support rod end of thread. With brackets in position as shown at section B-B, assemble bottom support brackets 73396 and nut Y12-112-C, so that slot in bracket engages rim of cover. Adjust support bracket to level the cover. (Clamp 60209 may have to be further adjusted to allow cover to rest squarely on drum.) Tighten Y12-112-C nuts to secure cover and brackets.
5. Insert pump thru hole in cover and secure in place.

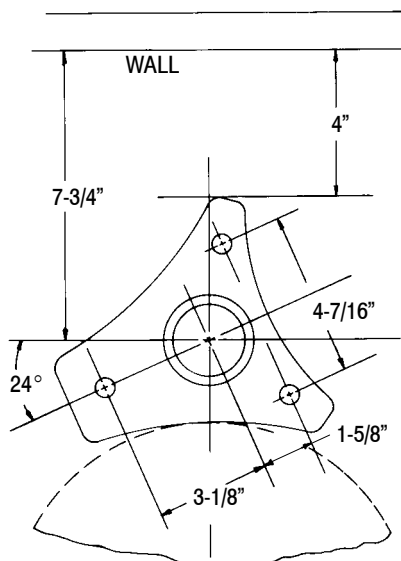

USE 1/2" DIA. X 1-1/2" LAG SCREWS FOR FASTENING TO FLOOR

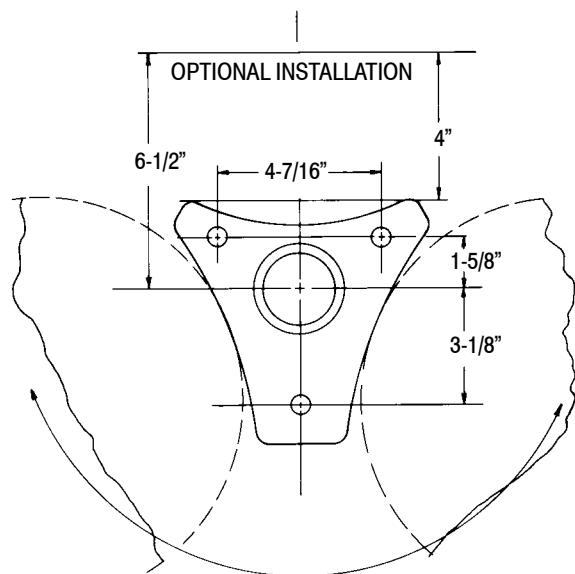

### OPERATING HINTS

1. To raise pump, disconnect air hose to pump and connect to air valve at base of lift. NOTE: An extra Y45-103-C bushing comes with lift, so you may adapt it to accept either standard (Aro 210) or heavy duty (Aro 310) Air Line Speed Coupler.
2. To lower, remove air line coupler. Lift will drop slowly into lowered position.

**PARTS LIST / 640067**

