

# OPERATOR'S MANUAL

# 640152-X

INCLUDING: OPERATION, INSTALLATION AND MAINTENANCE.

RELEASED: 8-22-80  
REVISED: 11-26-07  
(REV. C)

## 640152 (1-7/8" pump tube) 640152-1 (2-1/8" pump tube) Follower Plate Assembly (120# drum, gravity type)



**READ THIS MANUAL CAREFULLY BEFORE INSTALLING,  
OPERATING OR SERVICING THIS EQUIPMENT.**

It is the responsibility of the employer to place this information in the hands of the operator. Keep for future reference.

### FOLLOWER PLATE INSTRUCTIONS

#### Check the following before installation.

1. The pump tube must be smooth.
2. The follower plate must fit the pump tube with just a slight drag.
3. Excessively large dents in the container will prevent the follower plate from settling.

#### Installing the follower plate.

1. Place the follower plate in the container, then press down until the material is forced through the pump tube grommet, thus eliminating air between the follower plate and the material.
2. The pump must center on the container to prevent the follower plate from binding against the material container.

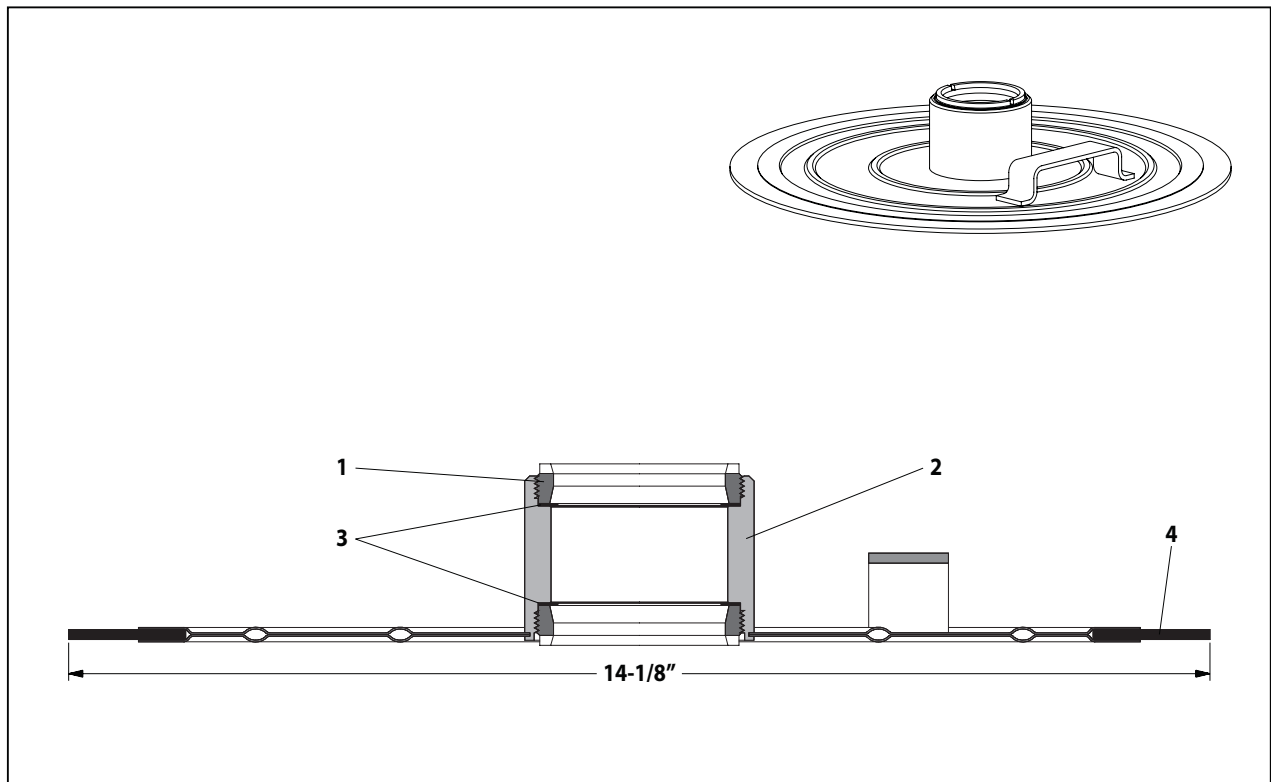

### 640152-X PARTS LIST

Item	Description (size)	(Qty)	Part No.
1	Follower Guide (models 640152)	(2)	76109-2
	(models 640152-1)	(2)	76109-5
2	Follower Plate Assembly	(1)	66645

Item	Description (size)	(Qty)	Part No.
3	Follower Seal (models 640152)	(2)	76110-2
	(models 640152-1)	(2)	76110-5
4	Follower Plate Seal	(1)	75760

PN 97999-409

INGERSOLL RAND COMPANY LTD  
P.O. BOX 151 • ONE ARO CENTER • BRYAN, OHIO 43506-0151  
① (800) 276-4658 • FAX (800) 266-7016

© 2007

CCN 81379737

# ARO

**IR** Ingersoll Rand  
Industrial Technologies