

OPERATOR'S MANUAL & SALES AND ENGINEERING DATA

INCLUDING: SPECIFICATIONS, SERVICE KITS, GENERAL INFORMATION, PARTS, TROUBLESHOOTING
 INCLUDE MANUAL: AF044X-XX AIR MOTOR (97999-1466) & S-633 GENERAL INFORMATION (PN 97999-625)

RELEASED: 9-15-10
 (REV. 01)

4-1/4" AIR MOTOR
 50:1 RATIO
 0 - 7500 PSI RANGE

AF0450LXXXXXX-XX-X BASIC GREASE PUMP



**READ THIS MANUAL CAREFULLY BEFORE INSTALLING,
 OPERATING OR SERVICING THIS EQUIPMENT.**

It is the responsibility of the employer to place this information in the hands of the operator. Keep for future reference.

SERVICE KITS

- Use only genuine ARO® replacement parts to assure compatible pressure rating and longest service life.
- ~~637485~~ Packing Kit. ← **Superseded: 65130**
- **637489** for Air Motor Service Only.

SPECIFICATIONS

Model Series	AF0450LXXXXXX-XX-X
Type	Air Operated, Grease Pump
Ratio	50:1
Air Motor Diameter	4-1/4" (10.8 cm)
Stroke	4" (10.2 cm)
Air Inlet	1/2 - 14 n.p.t.f. (f)
Material Outlet	1/2 - 14 n.p.t.f. (f)
Dimensional Data	See Chart

PERFORMANCE

Air Inlet Pressure Range	0 - 150 p.s.i. (0 - 10 bar)
Fluid Pressure Range	0 - 7500 p.s.i. (0 - 517 bar)
Maximum Delivery / Min.	6 lbs (2.7 kg)

GENERAL DESCRIPTION

These ARO pumps are designed to handle heavy greases and oils.

IMPORTANT

This is one of three documents which support the pump.
 Replacement copies of these forms are available upon request.

- AF0450LXXXXXX-XX-X MODEL OPERATOR'S MANUAL (PN 97999-1502)
- AF044X-XX AIR MOTOR OPERATOR'S MANUAL (PN 97999-1466)
- S-633 GENERAL INFORMATION LUBRICATION PISTON PUMPS (PN 97999-625)

⚠ WARNING READ THE GENERAL INFORMATION MANUAL INCLUDED FOR ADDITIONAL OPERATING AND SAFETY PRECAUTIONS AND OTHER IMPORTANT INFORMATION.

PUMP DATA

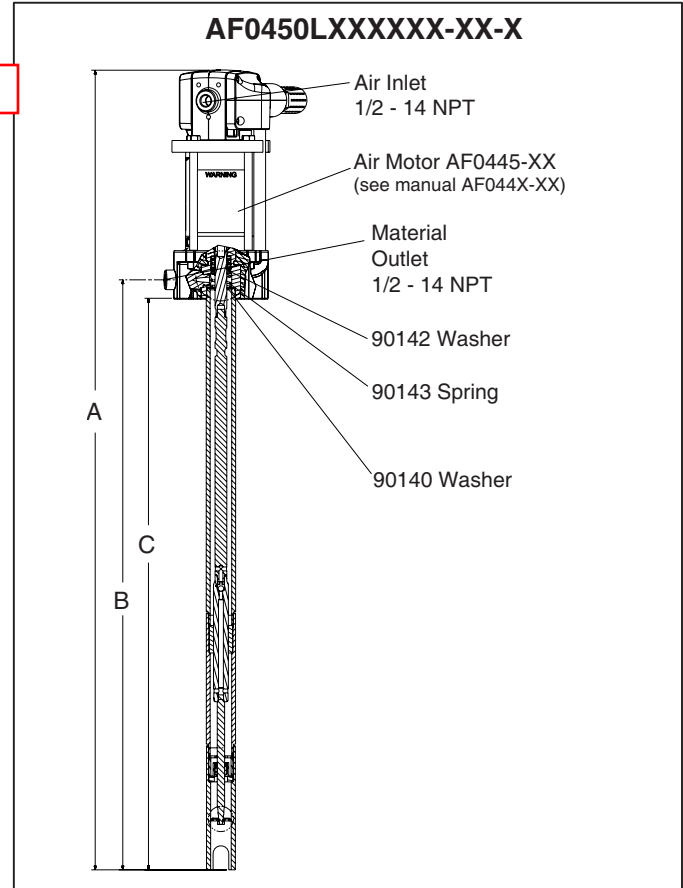

Note: Dimensions are shown in inches and are supplied for reference only.

	"A"	"B"	"C"	Container Suitability
AF0450L4	42.894"	29.507"	28.331"	16 Gallon (120 lbs)
AF0450L5	51.019"	37.632"	36.456"	55 Gallon (400 lbs)
(for -1 model)				
AF0450L4	44.974"	29.507"	28.331"	16 Gallon (120 lbs)
AF0450L5	53.104"	37.632"	36.456"	55 Gallon (400 lbs)

PARTS LIST / LOWER PUMP END

ITEM	DESCRIPTION (Size in Inches)	QTY	PART NO.
1	Rod (AF0450L51DK1-X)	(1)	90127
	(AF0450L41DK1-X)	(1)	92291
2	Tube (AF0450L51DK1-X)	(1)	90128
	(AF0450L41DK1-X)	(1)	92292
3	Ball	(1)	Y16-211
4	Piston Assembly	(1)	65036
5	Tube	(1)	90135
6	Rod	(1)	90131
7	Washer	(1)	90136
8	Sleeve	(1)	4170
9	Washer	(1)	92845
10	Washer	(1)	90138
11	Nut	(1)	95977302
12	Tube	(1)	90129
13	Ring	(1)	Y147-77
14	Packing	(1)	90757
15	Body	(1)	90756
16	Seat	(1)	4169
17	Washer	(1)	90133

OPERATING AND SAFETY PRECAUTIONS

⚠ WARNING EXCESSIVE INLET PRESSURE. Can cause explosion resulting in severe injury or death. Do not exceed maximum operating pressure of 7500 p.s.i. (517 bar) at 150 p.s.i. (10 bar) inlet air pressure. Do not run pump without using a regulator to limit air supply pressure to the pump.

⚠ WARNING EXCESSIVE MATERIAL PRESSURE. Can cause equipment failure resulting in severe injury or property damage. Do not exceed the maximum material pressure of any component in the system.

$\frac{\text{PUMP RATIO} \times \text{INLET PRESSURE TO PUMP MOTOR}}{\text{MAXIMUM PUMP FLUID PRESSURE}}$
<p>Pump ratio is an expression of the relationship between the pump motor area and the lower pump end area. EXAMPLE: When 150 p.s.i. (10 bar) inlet pressure is supplied to the motor of a 4:1 ratio pump it will develop a maximum of 600 p.s.i. (41.4bar) fluid pressure (at no flow) - as the fluid control is opened, the flow rate will increase as the motor cycle rate increases to keep up with the demand.</p>

NOTICE: Thermal expansion can occur when the fluid in the material lines is exposed to elevated temperatures. Example: Material lines located in a non-insulated roof area can warm due to sunlight. Install a pressure relief valve in the pumping system.

TROUBLE SHOOTING

No material at outlet. (Pump continuously cycles).

- Empty material supply. Disconnect the air, replenish the material supply.
- Foreign matter is holding foot valve seats open in the lower pump tube assembly. Remove lower pump tube assembly and clean valve seats.

Pump operates sluggishly, tends to stick when air is applied or control is opened.

- Air motor is dirty or lacks lubrication. Clean air motor.
- Insufficient air pressure or volume of air. Check air supply.

- Clean threads with solvent and apply Loctite 271 Sealant to threads.

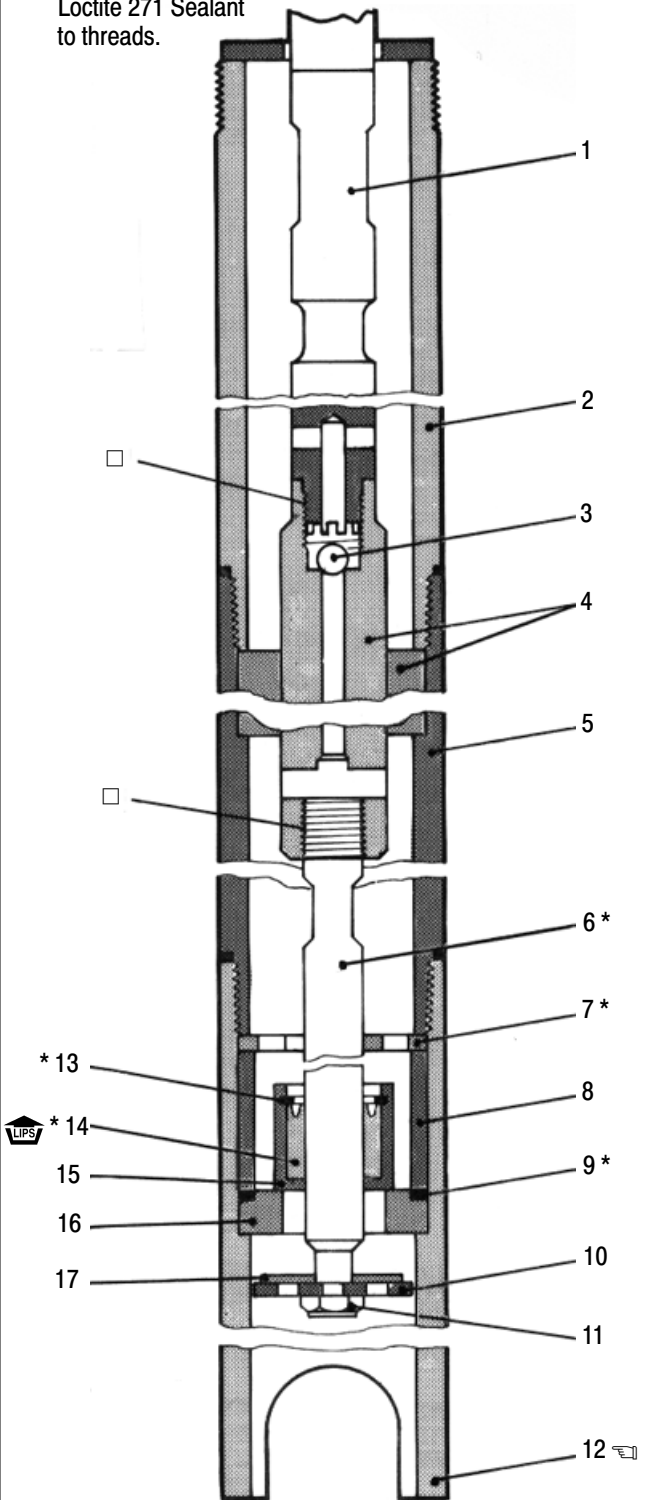

TORQUE REQUIREMENTS
(12) 260 - 300 ft lbs (352.6 - 406.8 Nm)

Air bypasses through exhaust port.

- Foreign matter is holding air valve open or lacks lubrication. Consult factory for nearest Service Center.

Motor stalls.

- Foreign matter in pump, hose, control valve or spray tip obstructing material flow. Check material supply hose and control valve tip.

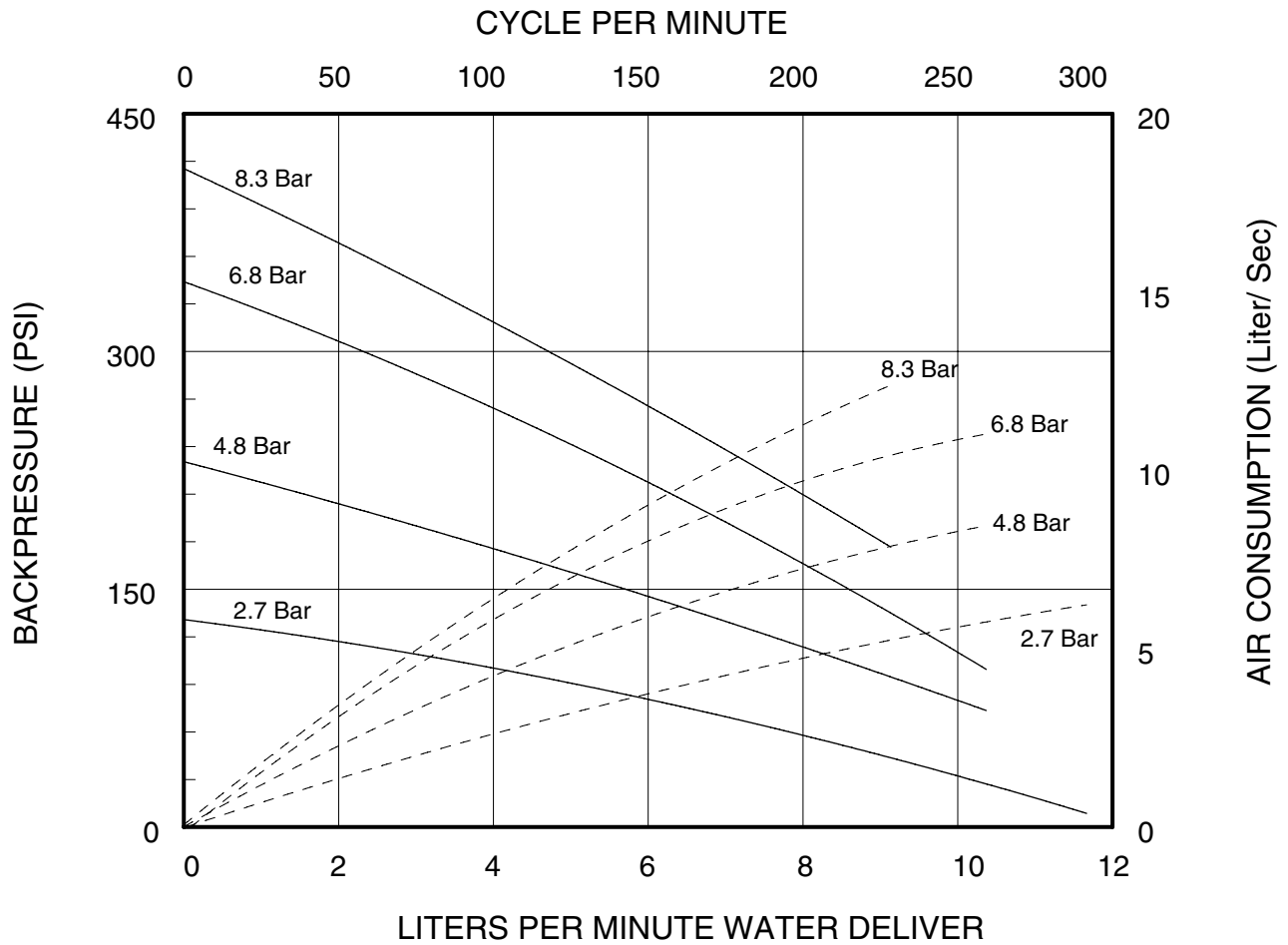
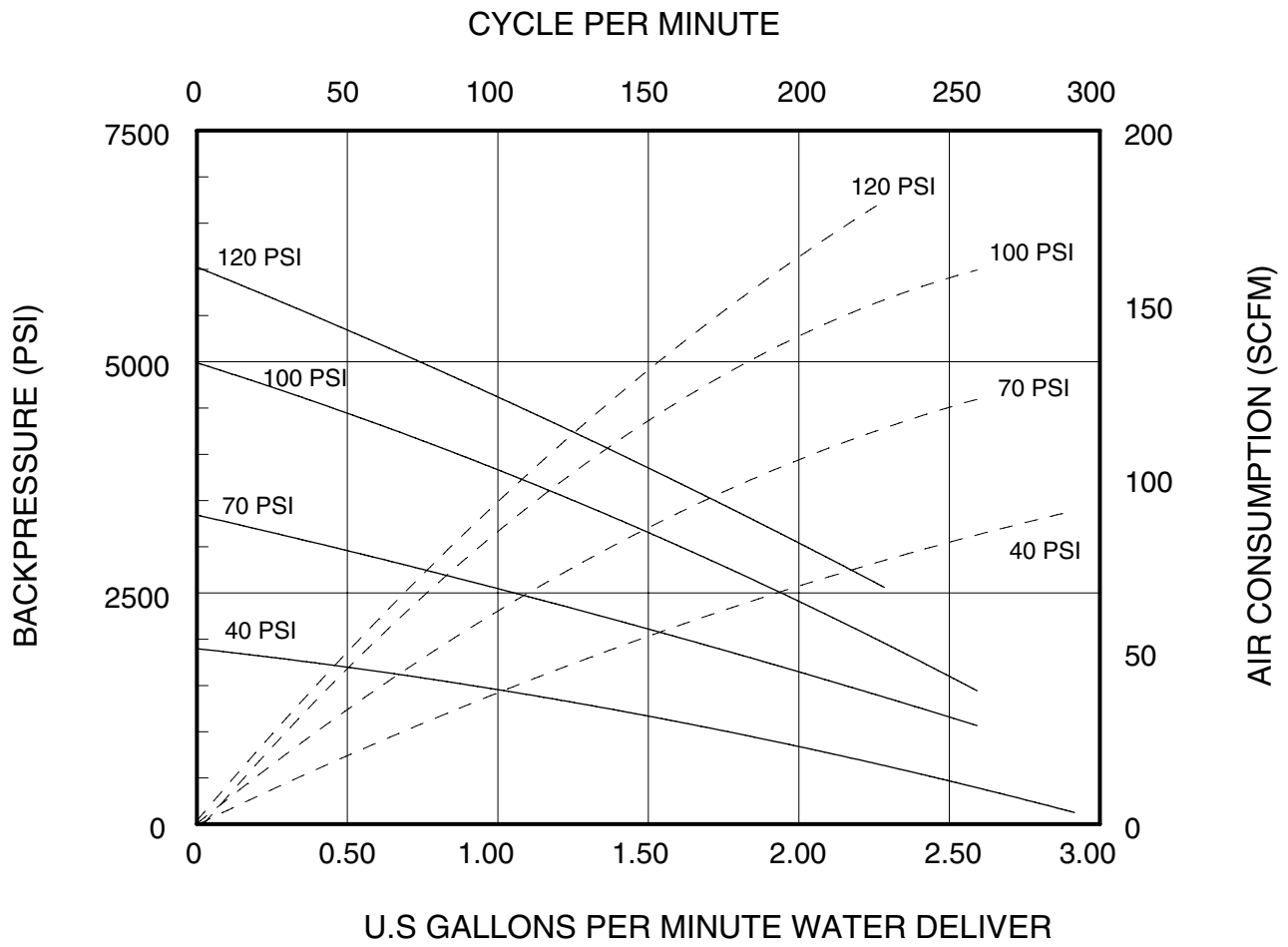

DIMENSIONS

TOP VIEW

