

OPERATOR'S MANUAL & SALES AND ENGINEERING DATA

INCLUDING: OPERATION, INSTALLATION & MAINTENANCE

INCLUDE MANUAL: AF06XX-XX Air Motor (pn 97999-1467) & S-632 GENERAL INFORMATION (PN 97999-694)

RELEASED: 9-30-10
(REV. 01)

**6" AIR MOTOR
100:1 RATIO
0 - 10,000 PSI. RANGE**

AF060BLXXXXX-XX-X PUMP ASSEMBLY



**READ THIS MANUAL CAREFULLY BEFORE INSTALLING,
OPERATING OR SERVICING THIS EQUIPMENT.**

It is the responsibility of the employer to place this information in the hands of the operator. Keep for future reference.

Per ARO (1/8/2016), use
part #: 63150

SERVICE KITS

- Use only genuine ARO® replacement parts to assure compatible pressure rating and longest service life.
- **637483** packing kit.
- **637489** for air motor service only.

SPECIFICATIONS

Model Series AF060BLXXXXX-XX-X.
Type Air Operated Grease Pump
Ratio 100:1
Air Motor Diameter..... 6" (15.2 cm)
Stroke..... 4" (10.2 cm)
Air Inlet (female) 1/2-14 N.P.T.F.
Material Outlet (female)..... 1/2 - 14 N.P.T.F.
Dimensional Data see chart

PERFORMANCE

Air Inlet Pressure Range..... 0 - 100 p.s.i.g (0 - 6.9 bar)
Fluid Pressure Range 0 - 10,000 p.s.i.g (0 - 690 bar)
Maximum Delivery/ Min 2.1 lbs (0.95 kg)

OPERATING AND SAFETY PRECAUTIONS

⚠ WARNING READ THE GENERAL INFORMATION MANUAL INCLUDED FOR ADDITIONAL OPERATING AND SAFETY PRECAUTIONS AND OTHER IMPORTANT INFORMATION.

⚠ WARNING EXCESSIVE INLET PRESSURE. Can cause explosion resulting in severe injury or death. Do not exceed maximum operating pressure of 10,000 p.s.i.g (690 bar) at 100 p.s.i.g (6.9 bar) inlet air pressure. Do not run pump without using a regulator to limit air supply pressure to the pump.

⚠ WARNING EXCESSIVE MATERIAL PRESSURE. Can cause equipment failure resulting in severe injury or property damage. Do not exceed the maximum material pressure of any component in the system.

PUMP RATIO X INLET PRESSURE TO PUMP MOTOR	=	MAXIMUM PUMP FLUID PRESSURE
--	---	--------------------------------

Pump ratio is an expression of the relationship between the pump motor area and the lower pump end area. EXAMPLE: When 100 p.s.i.g (6.9 bar) inlet pressure is supplied to the motor of a 100:1 ratio pump it will develop a maximum of 10,000 p.s.i.g (690 bar) fluid pressure (at no flow) - as the fluid control is opened, the flow rate will increase as the motor cycle rate increases to keep up with the demand.

NOTICE Thermal expansion can occur when the fluid in the material lines is exposed to elevated temperatures. Example: Material lines located in a non-insulated roof area can warm due to sunlight. Install a pressure relief valve in the pumping system.

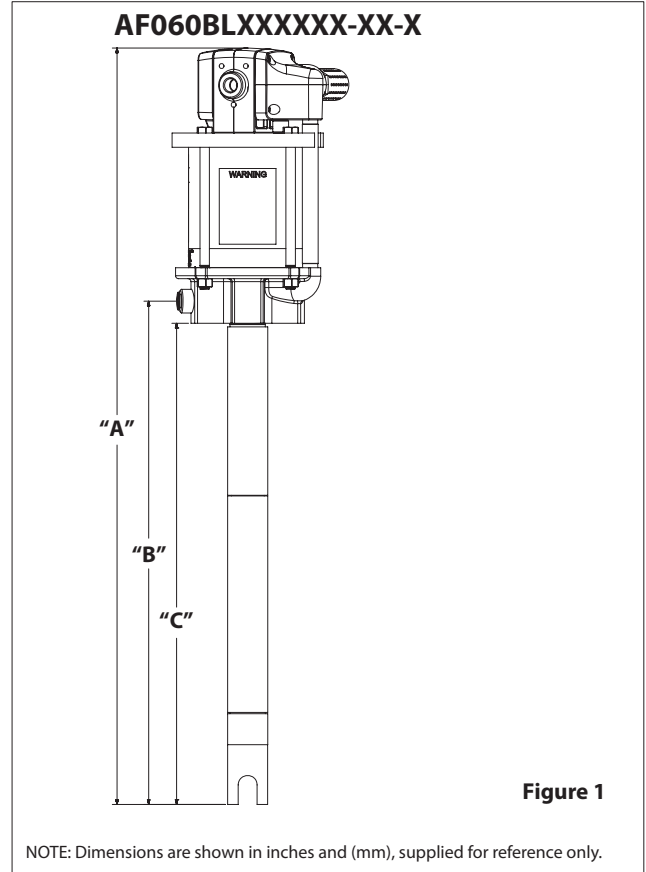

Figure 1

NOTE: Dimensions are shown in inches and (mm), supplied for reference only.

MODELS	"A" (mm)	"B" (mm)	"C"
AF060BL4XXXXX	40.010" (1016.3)	26.622" (676.2)	25.466" (646.8)
AF060BL4XXXXX-1	42.094" (1069.2)	26.622" (676.2)	25.466" (646.8)
AF060BL5XXXXX	49.822" (1265.5)	36.434" (925.4)	35.258 (895.6)
AF060BL5XXXXX-1	51.906" (1318.4)	36.434" (925.4)	35.258 (895.6)

IMPORTANT

This is one of six documents which support the pump. Replacement copies of these forms are available upon request.

- AF060BLXXXXX-XX-X MODEL OPERATOR'S MANUAL (97999-1511)
- AF06XX-XX AIR MOTOR OPERATOR'S MANUAL (97999-1467)
- S-632 GENERAL INFORMATION LUBRICATION PISTON PUMPS (97999-694)

PARTS LIST / LOWER PUMP END

Item	Description (size in inches)	Qty	Part No.
9	Tube	(1)	92627
15	Primer Tube	(1)	92626
16	Gasket	(1)	92628
19	Foot Valve Sleeve	(1)	4170
20	Ball Guide	(1)	92623
21	Body	(1)	90756
22	Foot Valve Seat	(1)	93269-1
23	Washer	(1)	F21-56
25	Tube (AF060BL43PKL1, AF060BL43PKL1-1)	(1)	92625-1
	(AF060BL53PKL1, AF060BL53PKL1-1)	(1)	92625-2
27	Ball	(1)	Y16-211
28	Piston and Cylinder	(1)	66714
30	Primer Rod	(1)	90131
31	Washer	(1)	90133
32	Washer	(1)	92630
33	Elastic Stop Nut	(1)	95977302
34	Rod (AF060BL43PKL1, AF060BL43PKL1-1)	(1)	92629-1
	(AF060BL53PKL1, AF060BL53PKL1-1)	(1)	92629-2
36	Adapter	(1)	92621
37	Snap Ring	(1)	Y147-77
40	Pin	(1)	92624
44	Washer	(1)	90136
65	Cup	(1)	90757

INSTALLATION

Remove pump from packaging material and install and secure pump to cover, bung or other mounting accessory as ordered. See figure 2 for view of complete assembly.

1. Before connecting pump, first blow out material line with air.
2. After the system is hooked up, pump a small amount of material through the line. This material should be discarded. (Do this to clear any foreign material out of lines).

OPERATING INSTRUCTIONS

Be sure material hose, lines and other components are able to withstand pressure developed by pumps.

1. When a pump is installed and ready to operate: Connect air supply to air motor inlet. Regulate air pressure from p.s.i.g (2.07 bar) to 50 p.s.i.g (3.4 bar). Allow pump to cycle slowly to prime with material and bleed all air from system.

MAINTENANCE

If the pump is to be inoperative for a lengthy period of time (a few hours), disconnect air and relieve all pressure from system. Periodically flush pump with a solvent that is compatible with material being pumped.

Disassembly should be done on a clean work bench with clean cloths to keep parts clean.

If replacement parts are necessary, consult drawings containing parts for identification.

Before reassembling, lubricate parts where required. When assembling "O" rings or parts adjacent to "O" rings, care must be exercised to prevent damage to "O" rings and "O" ring groove surfaces.

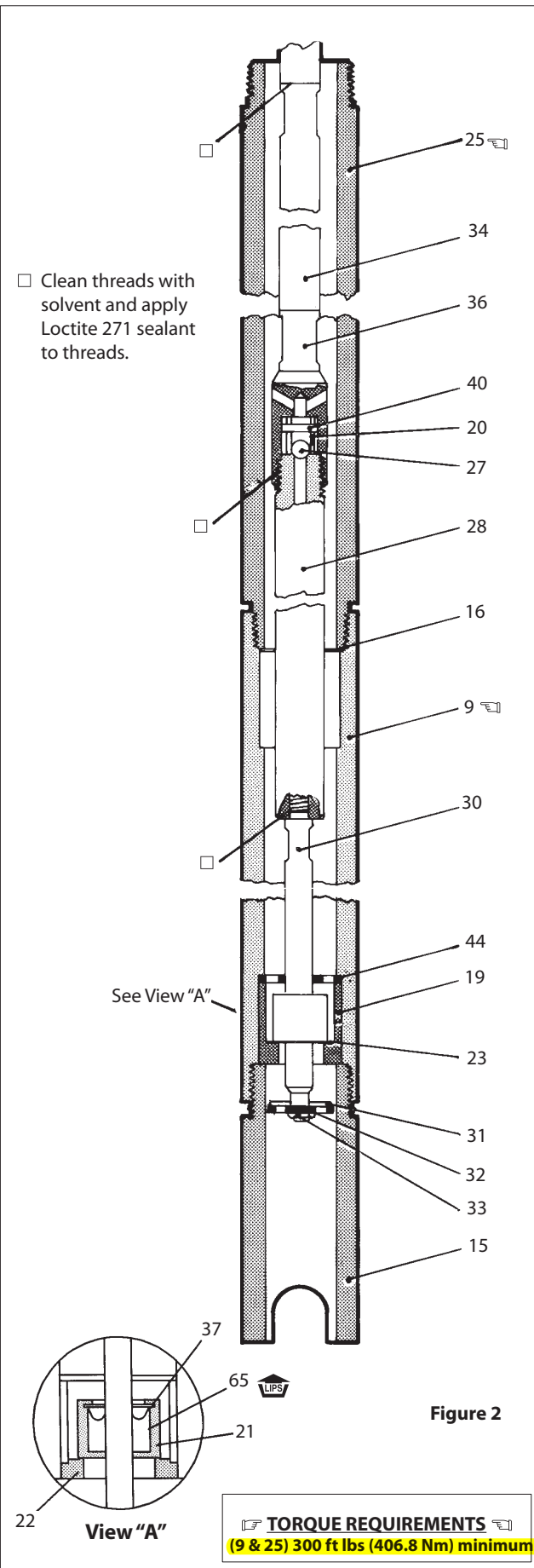

Figure 2

TORQUE REQUIREMENTS
(9 & 25) 300 ft lbs (406.8 Nm) minimum.

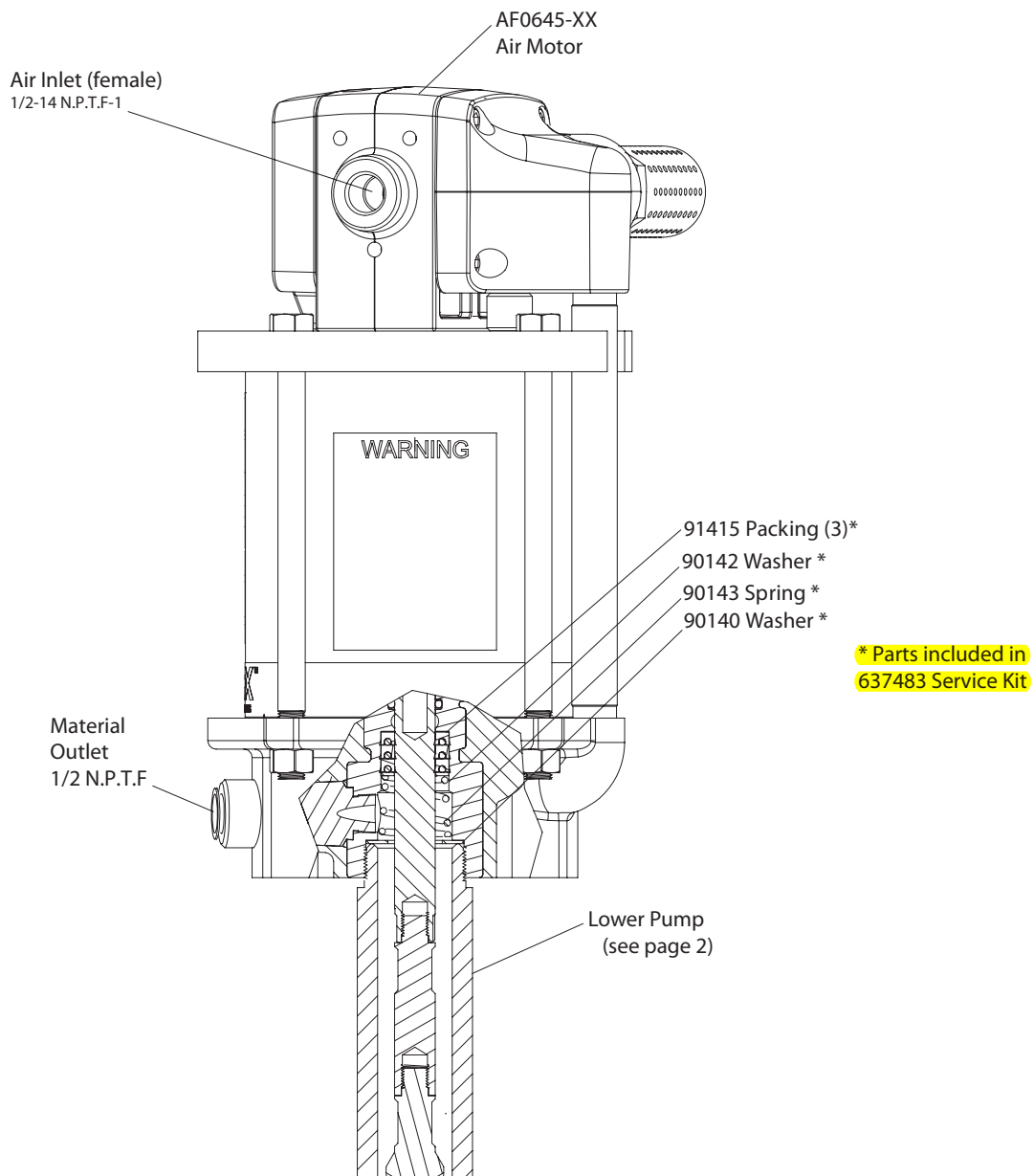

Figure 3

TROUBLE SHOOTING

No material at outlet. (Pump continuously cycles).

- Empty material supply. Disconnect the air, replenish the material supply.
- Foreign matter is holding foot valve seats open in lower pump tube assembly. Remove lower pump tube assembly and clean valve seats.

Pump operates sluggishly, tends to stick when air is applied or control is opened.

- Air motor is dirty or lacks lubrication. Clean air motor.
- Insufficient air pressure or volume of air. Check air supply.

Air bypasses through exhaust port.

- Foreign matter is holding air valve open or lacks lubrication. Consult factory for nearest Service Center.

Motor stalls.

- Foreign matter in pump, hose, control valve or spray tip obstructing material flow. Check material supply hose and control valve or tip.
- Air not getting to pump. Check air supply.

PERFORMANCE CURVES

