

OPERATOR'S MANUAL

LM2203A-X-C

INCLUDING: SPECIFICATIONS, SERVICE KITS, GENERAL INFORMATION, PARTS, TROUBLESHOOTING
 INCLUDE MANUAL: S-632 GENERAL INFORMATION (PN 97999-624)

RELEASED: 12-27-04
 REVISED: 9-22-11
 (REV. 03)

2" AIR MOTOR
3:1 RATIO
0 - 450 P.S.I. RANGE



LM2203A-XX-C TWO-BALL PUMP SERIES



**READ THIS MANUAL CAREFULLY BEFORE INSTALLING,
 OPERATING OR SERVICING THIS EQUIPMENT.**

It is the responsibility of the employer to place this information in the hands of the operator. Keep for future reference.

SERVICE KITS

- Use only genuine ARO® replacement parts to assure compatible pressure rating and longest service life.
- **637224 Pump Rebuild Kit.** Includes the necessary soft parts for normal service of the entire pump.

SPECIFICATIONS

Model Series (refer to option chart)	LM2203A-XX-C
Type	Air Operated, Two Ball, Double Acting Oil Pump
Ratio	3:1
Air Motor Diameter	2" (5.08 cm)
Stroke	3" (7.62 cm)
Air Inlet (female)	
LM2203A-X1-C	1/4 - 18 N.P.T.F.
LM2203A-X2-C	Rp 1/4 (1/4 - 19 BSP Parallel)
Material Inlet (female)	
LM2203A-X1-C	3/4 - 14 N.P.T.
LM2203A-X2-C	Rp 3/4 (3/4 - 14 BSP Parallel)
Material Outlet (female)	
LM2203A-X1-C	1/2 - 14 N.P.T.F. - 1
LM2203A-X2-C	Rp 1/2 (1/2 - 14 BSP Parallel)
Pump Construction	Carbon Steel
Dimensional Data	See chart
Weight	See chart

PERFORMANCE

Air Inlet Pressure Range	0 - 150 p.s.i. (0 - 10.3 bar)
Fluid Pressure Range	0 - 450 p.s.i. (0 - 31.0 bar)
Maximum Rec'd Cycles / Minute	125
Displacement In³ Per Cycle	6.2
Volume / Cycle	3.46 oz. (102.28 ml)
Cycles Per Gallon (Liter)	37 (9.8)
Maximum Working Flow Rate	6 g.p.m. (23 l.p.m.)
Maximum Flow Rate	9 g.p.m. (34 l.p.m.)
Noise Level @ 100 p.s.i. - 124 c.p.m.	80 db(A)*
Accessories Available	61113 Wall Mount Bracket 66073-1 Air Line Connection Kit

* The pump sound pressure level has been updated to an Equivalent Continuous Sound Level (L_{Aeq}) to meet the intent of ANSI S1. 13-1971, CAGI-PNEUROP S5.1 using four microphone locations.

PUMP DATA

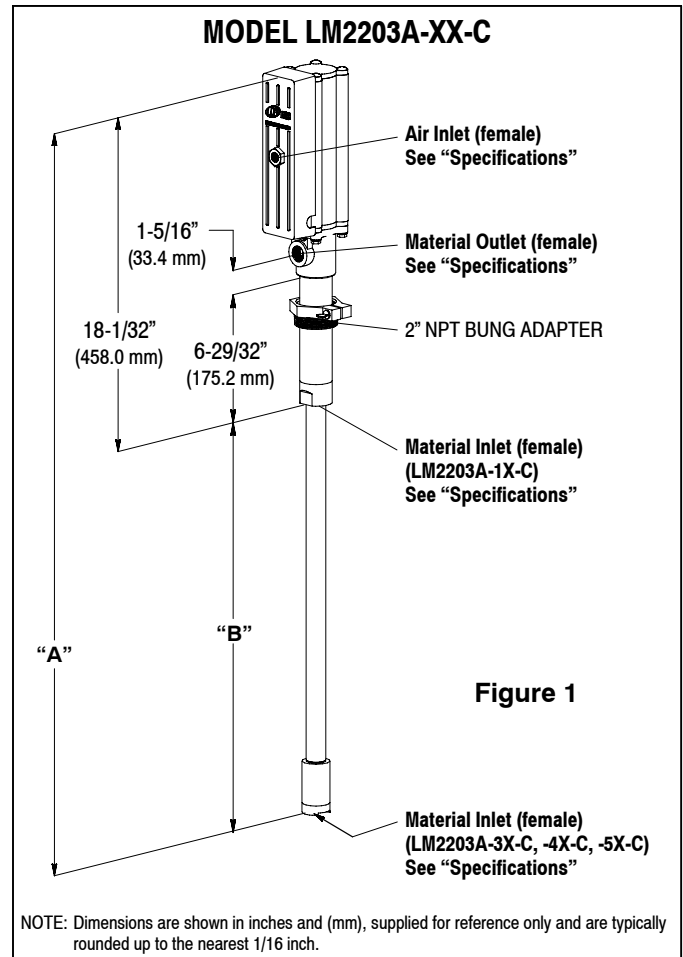

MODEL	"A" (mm)	"B" (mm)	WEIGHT (kg)
LM2203A-1X-C	N / A	N / A	11 (4.99)
LM2203A-3X-C	40-1/16" (1017.6)	22-1/32" (559.3)	13.5 (6.12)
LM2203A-4X-C	49-13/16" (1265.0)	31-25/32" (806.9)	14.4 (6.53)
LM2203A-5X-C	57-7/16" (1458.6)	39-13/32" (1000.6)	15 (6.80)

IMPORTANT

This is one of two documents which support the pump. Replacement copies of these forms are available upon request.

- LM2203A-X-C Model Operator's Manual
- S-632 General Information Lubrication Piston Pumps

PARTS LIST / LM2203A-XX-C

Item	Description (size)	(Qty)	Part No.
1	Bolt	(4)	94333
2	Upper Cap	(1)	94307
✓ 3	Track Gasket	(2)	94311
4	Sleeve	(2)	94316
✓ 5	“O” Ring (1/16” x 11/16” o.d.)	(4)	Y325-15
✓ 6	“O” Ring (1/8” x 3/4” o.d.)	(4)	Y325-206
7	Spool	(2)	94310
✓ 8	“U” Cup (1/8” x 3/4” o.d.)	(2)	Y240-7
✓ 9	“O” Ring (0.106” x 0.587” o.d.)	(2)	15066-PM
10	Muffler Housing	(1)	94443
11	Cylinder	(1)	94249
12	Retaining Ring	(1)	94406
✓ 13	“U” Cup (3/16” x 2” o.d.)	(2)	Y240-23
14	Piston	(1)	94780
15	Lower Cap	(1)	94308
✓ 16	“O” Ring (1/8” x 1-3/8” o.d.)	(1)	Y325-216
17	Bushing	(1)	94332
✓ 18	Packing (1/4” x 1-5/8” o.d.)	(1)	94337
✓ 19	“O” Ring (3/32” x 1” o.d.)	(1)	Y325-117
20	Piston Rod	(1)	94779
21	Groove Pin (3/16” o.d. x 1-1/8” long)	(1)	94338
22	Spring	(1)	94705
23	Ball (3/4” dia.)	(1)	Y16-224
24	Inner Check	(1)	94279
✓ 25	“O” Ring (3/16” x 1-7/16” o.d.)	(1)	Y325-319
26	Base - models LM2203A-()1-C	(1)	96253
	- models LM2203A-()2-C	(1)	96253-1
27	Nut	(4)	93828
✓ 28	Copper Gasket	(1)	96031
29	Tube	(1)	94314-1
✓ 30	“O” Ring (3/32” x 1-9/16” o.d.)	(1)	Y325-126
31	Ball (1” dia.)	(1)	Y16-232

Item	Description (size)	(Qty)	Part No.
32	Ball Stop Pin (0.187” dia. x 1.430” long)	(1)	94339
33	Foot Valve - models LM2203A-()1-C	(1)	94315
	- models LM2203A-()2-C	(1)	94315-1
✓ 34	“O” Ring (1/16” x 7/16” o.d.)	(1)	Y325-11
✓ 35	“O” Ring (1/16” x 3/4” o.d.)	(1)	Y325-16
36	Adapter - models LM2203A-()1-C	(1)	94447
	- models LM2203A-()2-C	(1)	94447-1
37	Foam Liner	(2)	94402
38	Ground Screw (#10 - 32 x 1/4”)	(1)	93005
39	Bung Assembly (includes items 40 and 49)	(1)	67145-3-B
40	Thumb Screw (1/4” - 20 x 1-1/2”)	(1)	Y197-158-C
41	Pipe Extension - models LM2203A-31-C	(1)	94523-3
	3/4 - 14 N.P.T. x 30-1/8” - models LM2203A-41-C	(1)	94523-4
	3/4 - 14 N.P.T. x 37-3/4” - models LM2203A-51-C	(1)	94523-5
	Rc 3/4 (3/4 - 14 BSP taper x 20-3/8”) - LM2203A-32-C	(1)	94537-3
	Rc 3/4 (3/4 - 14 BSP taper x 30-1/8”) - LM2203A-42-C	(1)	94537-4
	Rc 3/4 (3/4 - 14 BSP taper x 37-3/4”) - LM2203A-52-C	(1)	94537-5
42	Valve Housing - models LM2203A-()1-C	(1)	94535
	- models LM2203A-()2-C	(1)	94535-1
43	Ball Guide	(1)	77904
44	Ball (1” dia.)	(1)	Y16-232
✓ 45	“O” Ring (3/32” x 1-7/16” o.d.)	(1)	Y325-124
46	Ball Seat - models LM2203A-()1-C	(1)	94534
	- models LM2203A-()2-C	(1)	94534-1
47	Valve Assembly (includes items 42 thru 46)		
	models LM2203A-31-C, -41-C, -51-C	(1)	67085
	models LM2203A-32-C, -42-C, -52-C	(1)	67085-1
48	Washer	(1)	94515
49	Nut (1/4” - 20)	(1)	Y12-4-C
✓	Gadus S2 U1000 Grease Packet	(1)	94833
✓	Parts in Repair Kit		637224

GENERAL DESCRIPTION

Model LM2203A-X-C series two-ball double acting pumps are intended to be used primarily for oil transfer and delivery systems. It is best to use this pump with low – medium viscosity fluids. It uses carbon steel and other materials which make it compatible with most petroleum based lubrication products. The two-ball design provides better priming of the lower foot valve. Double acting pumps will deliver material on both the up and down stroke.

NOTE: If this pump was purchased separately (not part of a system), consult your sales representative for compatible dispensing accessories which will best match the application. All accessories must be able to withstand the maximum pressure developed by the pump.

OPERATING AND SAFETY PRECAUTIONS

⚠️ WARNING READ THE GENERAL INFORMATION MANUAL INCLUDED FOR ADDITIONAL OPERATING AND SAFETY PRECAUTIONS AND OTHER IMPORTANT INFORMATION.

⚠️ WARNING STATIC SPARK. Can cause explosion resulting in severe injury or death. Ground the pump and pumping system.

⚠️ WARNING EXCESSIVE INLET PRESSURE. Can cause ex-

plosion resulting in severe injury or death. Do not exceed maximum operating pressure of 450 p.s.i. (31.0 bar) at 150 p.s.i. (10.3 bar) inlet air pressure. Do not run pump without using a regulator to limit air supply pressure to the pump.

$$\text{PUMP RATIO X INLET PRESSURE TO PUMP MOTOR} = \text{MAXIMUM PUMP FLUID PRESSURE}$$

Pump ratio is an expression of the relationship between the pump motor area and the lower pump end area. EXAMPLE: When 150 p.s.i. (10.3 bar) inlet pressure is supplied to the motor of a 3:1 ratio pump it will develop a maximum of 450 p.s.i. (31.0 bar) fluid pressure (at no flow) – as the fluid control is opened, the flow rate will increase as the motor cycle rate increases to keep up with the demand.

⚠️ WARNING EXCESSIVE MATERIAL PRESSURE. Can cause equipment failure resulting in severe injury or property damage. Do not exceed the maximum material pressure of any component in the system.

NOTICE: Thermal expansion can occur when the fluid in the material lines is exposed to elevated temperatures. Example: Material lines located in a non-insulated roof area can warm due to sunlight. Install a pressure relief valve in the pumping system. Replacement warning label (pn 94520) is available upon request.

PARTS LIST / LM2203A-XX-C

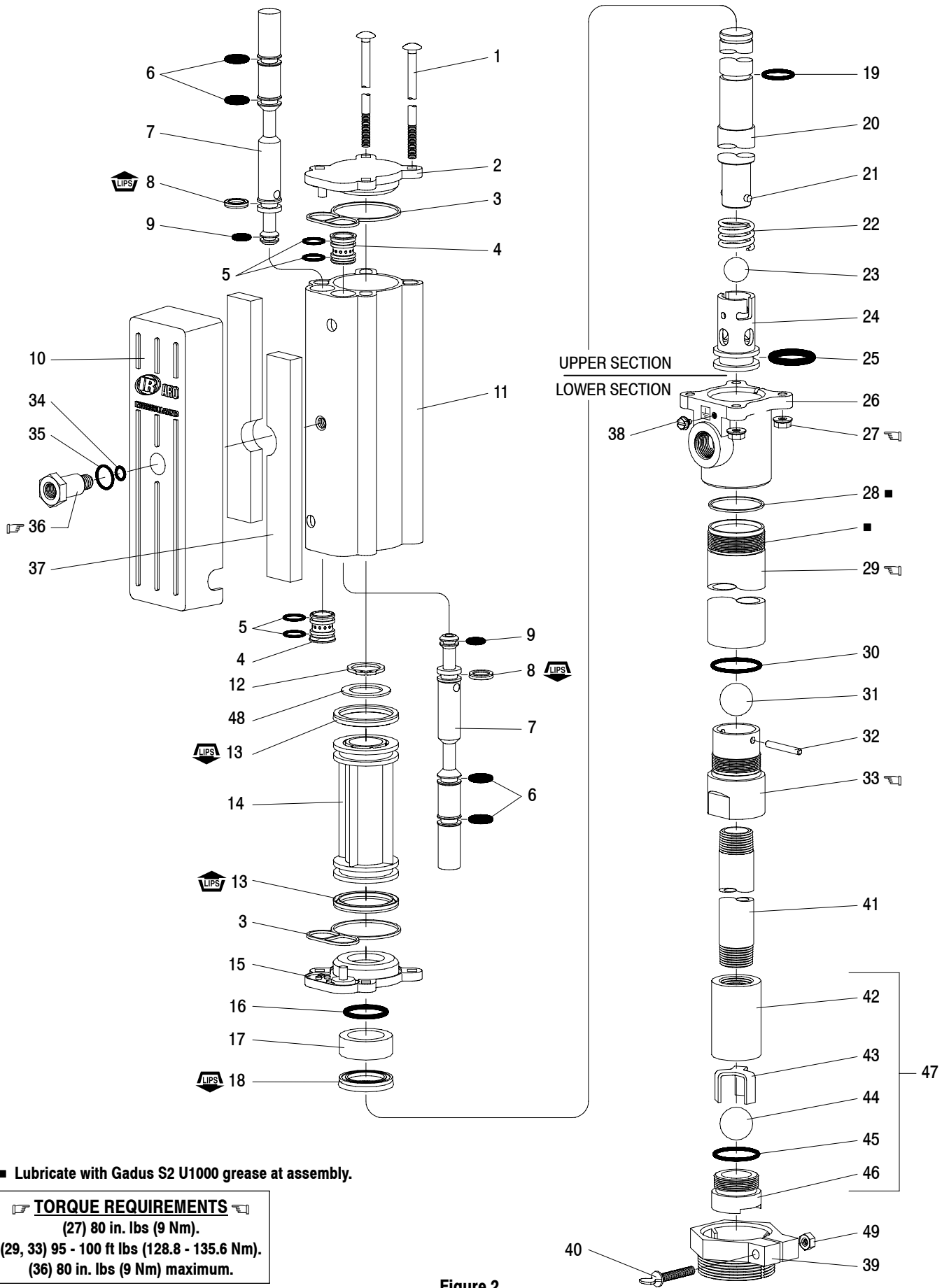

■ Lubricate with Gadus S2 U1000 grease at assembly.

TORQUE REQUIREMENTS
 (27) 80 in. lbs (9 Nm).
 (29, 33) 95 - 100 ft lbs (128.8 - 135.6 Nm).
 (36) 80 in. lbs (9 Nm) maximum.

Figure 2

PLACING INTO SERVICE

AIR AND LUBRICATION REQUIREMENTS

Filtered air will help extend the life of the pump, allowing the pump to operate more efficiently and yield longer service life to moving parts and mechanisms.

- Install an air line filter to provide good quality clean and dry air. Install it up stream from the regulator.
- Use an air regulator on the air supply to control the pump cycle rate. Install the regulator as close as possible to the pump.
- In most installations, lubrication is not required. If the pump needs to have lubrication, install an air line lubricator and supply it with a good grade of non-detergent oil or other lubricant compatible with Nitrile seals and set at a rate not to exceed one drop per minute.

INSTALLATION

- Mount and secure the pump as required for the application.
- Attach a ground wire from the pump ground screw to a suitable ground.
- Connect a fluid hose to the pump outlet. In most cases a pipe sealant

should be used on thread connection. Tighten all fittings. Use caution not to damage threads.

OPERATION

START-UP

1. Turn the air regulator to "0" pressure setting.
2. Immerse the lower pump end into the material.
3. Open the dispensing device.
4. Start the pump cycling slowly by raising the pressure to 20 - 30 p.s.i. (1.4 - 2.1 bar).
5. Close the dispensing device. Allow the pump to stall and build line pressure. Check for any leaks and tighten fittings as needed. Adjust pressure as required for the application.

SHUTDOWN

- Disconnect the air supply from the pump if it is to be inactive for a few hours. Open the dispensing device to relieve line pressure.

SERVICE

PUMP DISASSEMBLY / REASSEMBLY

NOTICE: The unique design of this pump allows for quick basic pump service without total removal from the drum (refer to the views below). **DISASSEMBLY - All threads are right hand. Refer to figure 2. These procedures are for the installation of repair kit parts. Disconnect air supply and relieve all system pressure prior to servicing.** Carefully remove the parts, inspect parts for damage, nicks or excessive wear and determine if any parts will need replacement.

Follow the three disassembly steps in the detail views below and place the pump on a clean bench.

1. Remove (1) bolts. Remove (18) packing, (17) bushing and (16) "O" ring.
2. Remove (36) adapter, releasing (10) muffler housing.
3. Grasp the (11) cylinder and remove the (20, 14) piston assembly.
4. Remove (15) lower cap and (3) track gasket. Remove (12) retaining ring and (48) washer, then pull (14) piston off (20) piston rod.
5. Remove (2) cap and (3) track gasket. Push on the large o.d. end of the (7) spool to remove the (4) sleeve. Grab the nose of (7) spool and pull out. Repeat for other sleeve and spool.

REASSEMBLY - Thoroughly clean and lubricate all seals and bores with Shell Gadus S2 U1000 upon assembly. Replace all soft parts with new ones included in the repair kit.

Note: Refer to the illustration (figure 2) for "U" cup lip seal direction.

1. Replace the seals on both the (7) spools and (4) sleeves.

2. Locate the valve chamber on the (11) cylinder where the 3/8" dia. hole is located and install one of the (4) sleeves. Insert the (7) spool from the opposite end. Next, install the remaining sleeve and spool.
3. Replace the (3) track gasket and install (2) cap.
4. Replace the (13) piston "U" cups (refer to figure 2 for proper orientation). Replace the (19) "O" ring and assemble (14) piston to (20) piston rod and retain with (48) washer and (12) retaining ring.
5. Install the (20, 14) piston assembly using great care to collapse the outer lip of the second "U" cup, allowing it to slip into the cylinder.
6. Replace the (3) track gasket and install the (15) cap. Install the (16) "O" ring onto the piston rod, replace (17) bushing and (18) packing.
7. Replace the (25) "O" ring and re-attach the (24) inner check.
8. Slide the pump assembly back into the (26) base / lower pump section. Press the sections together and align the air inlet and pump outlet as required and replace the four (1) bolts and (27) nuts (tighten to 80 in. lbs (9 Nm).

TROUBLE SHOOTING

If the pump will not cycle or will not deliver material.

- Be certain to check for non-pump problems including kinked, restrictive or plugged inlet / outlet hose or dispensing device. Depressurize the pump system and clean out any obstructions in the inlet / outlet material lines.
- Check all seals, including track gaskets.
- Check direction of "U" cup lips.

PUMP DISASSEMBLY DETAIL

A) Remove the four nuts from the base of the Air Motor.

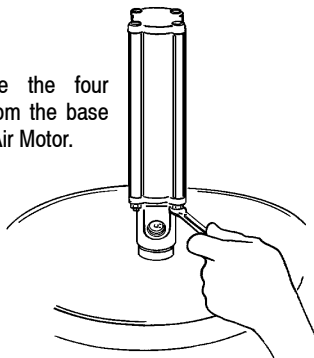

Figure 3

B) Grasp the lower motor cap and pull out the motor and upper section of the lower section.

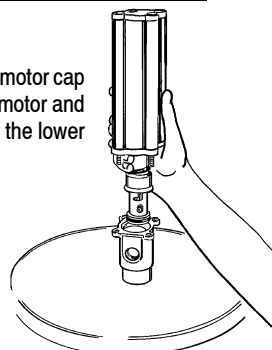

Figure 4

C) Unlock the (24) inner check from the piston rod.

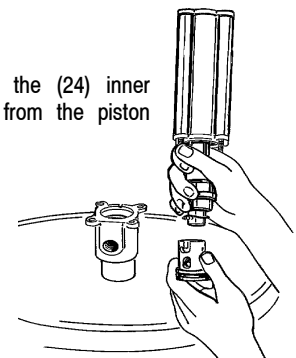

Figure 5