

AMERICAN

LUBRICATION EQUIPMENT CORPORATION

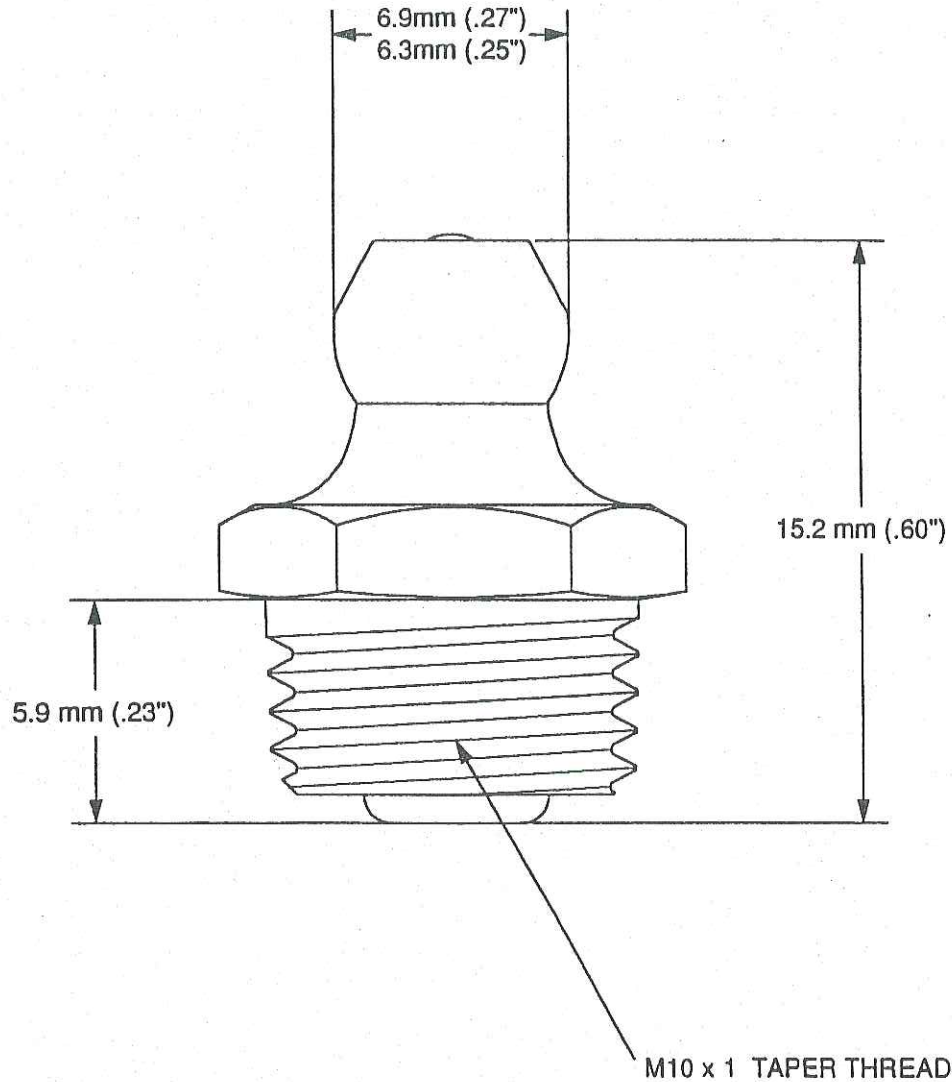

ACTUAL SIZE

DESCRIPTION		STRAIGHT HYDRAULIC GREASE FITTING WITH CHECK VALVE		AMERICAN LUB. CODE No. T7404	
MATERIAL 11mm(7/16") A/F HEXAGON MILD STEEL	HEAT TREATMENT CASE HARDENED	SURFACE TREATMENT ZINC PLATED YELLOW CHROMATED		TOLERANCE $\pm 0.7\text{mm}$ (.030") UNLESS OTHERWISE STATED	
CAD DRAWING SCALE 5:1	COMPILER & DATE R.H. 21.09.92	CHECKED BY & DATE A.B. 29.01.93		ISSUE DATE 1. 12. 1993	