

AMERICAN

LUBRICATION EQUIPMENT CORPORATION

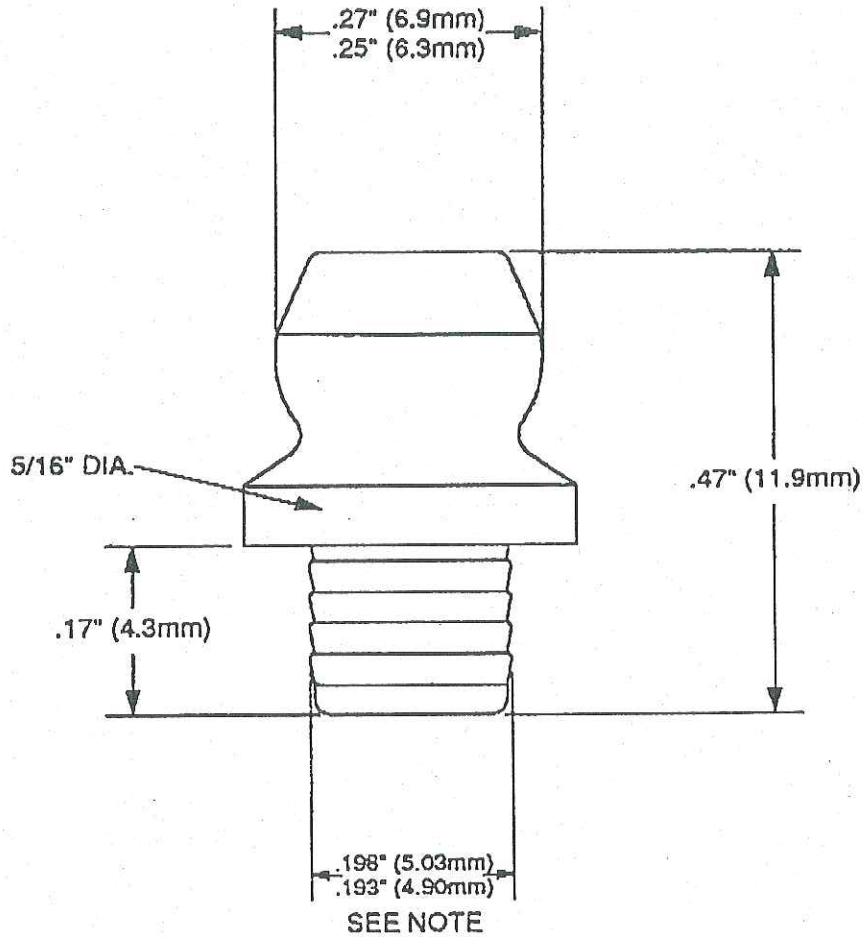

ACTUAL SIZE

NOTE:
 SUITABLE FOR A 3/16" DIA.
 NOMINAL HOLE SIZE.
 THIS IS FOR GUIDANCE ONLY.
 ACTUAL SIZE MUST BE
 DETERMINED BY TEST DRILLING

DESCRIPTION: 3/16" DRIVE FIT
 STRAIGHT HYDRAULIC GREASE FITTING - NO BALL CHECK

CODE NUMBER: T-7603

MATERIAL:
 5/16" (8mm) DIA. ROUND
 M07 PB MILD STEEL

HEAT TREATMENT:
 CARBO-NITRIDED
 CASE HARDENED

PLATING:
 ZINC,
 BRIGHT BLUE PASSIVATED

TOLERANCES:
 SHANK LENGTH: ±.03" (0.8mm)
 OTHER: ±.04" (1.0mm) UNLESS STATE

**CAD
 DRAWING
 SCALE** 5:1

COMPILER & DATE:
 R.H.
 27.03.96

CHECKED BY & DATE:
 J.A.F.
 27.03.96

ISSUE DATE:
 27. MAR 1996