

# AMERICAN

LUBRICATION EQUIPMENT CORPORATION

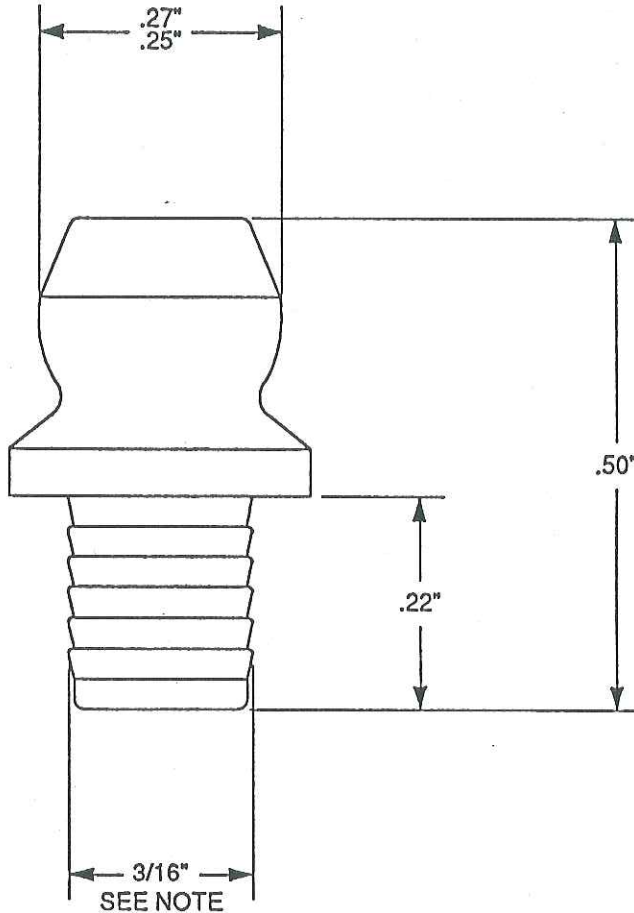

ACTUAL SIZE

**NOTE**

SUITABLE FOR A  $3/16''$  DIAMETER NOMINAL HOLE SIZE. THIS IS FOR GUIDANCE ONLY. ACTUAL SIZE MUST BE DETERMINED BY TEST DRILLING

DESCRIPTION:

3/16" DRIVE FIT  
STRAIGHT HYDRAULIC GREASE FITTING  
NO BALL CHECK

DR-3/16-NB

AMERICAN LUB. CODE No. T7606

MATERIAL:  
5/16" DIA. ROUND  
230 M07 Pb MILD STEEL

HEAT TREATMENT:  
CARBO-NITRIDED  
CASE HARDENED

PLATING:  
ZINC,  
YELLOW CHROMATED

TOLERANCES:  
SHANK LENGTH:  $\pm .03''$   
OTHER:  $\pm .04''$  UNLESS STATED

CAD  
DRAWING  
SCALE      5:1

COMPILER & DATE:  
R.H.  
08.04.93

CHECKED BY & DATE:  
A.B.  
19.04.93

ISSUE DATE:  
22 Apr 1993