

AMERICAN

LUBRICATION EQUIPMENT CORPORATION

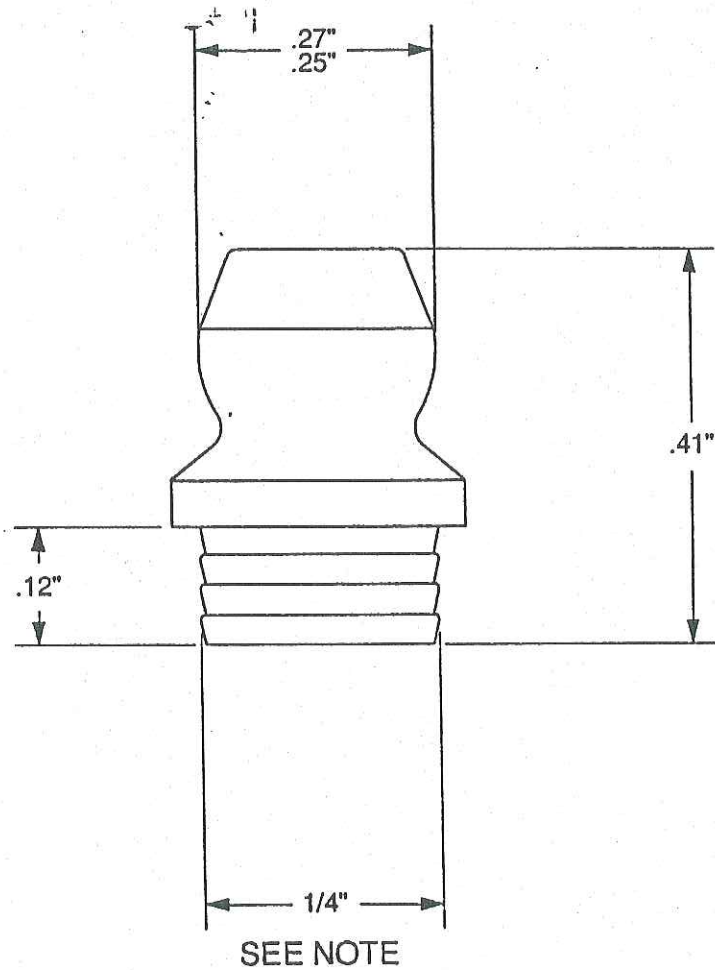

ACTUAL SIZE

NOTE

SUITABLE FOR A 1/4" DIA. NOMINAL HOLE SIZE. THIS IS FOR GUIDANCE ONLY. ACTUAL SIZE MUST BE DETERMINED BY TEST DRILLING

DESCRIPTION DRIVE FIT GREASE FITTING - NO BALL CHECK

AMERICAN LUB. CODE No. **T7607**

MATERIAL
5/16" DIA. ROUND
230 M07 Pb MILD STEEL

HEAT TREATMENT
CASE HARDENED

SURFACE TREATMENT
ZINC PLATED
YELLOW CHROMATED

TOLERANCE $\pm .030"$
UNLESS OTHERWISE STATED

CAD
DRAWING SCALE **5:1**

COMPILER & DATE
R.H.
12.01.93

CHECKED BY & DATE
J.A.F.
13 01 93

ISSUE DATE

11.18.93