

AMERICAN

LUBRICATION EQUIPMENT CORPORATION

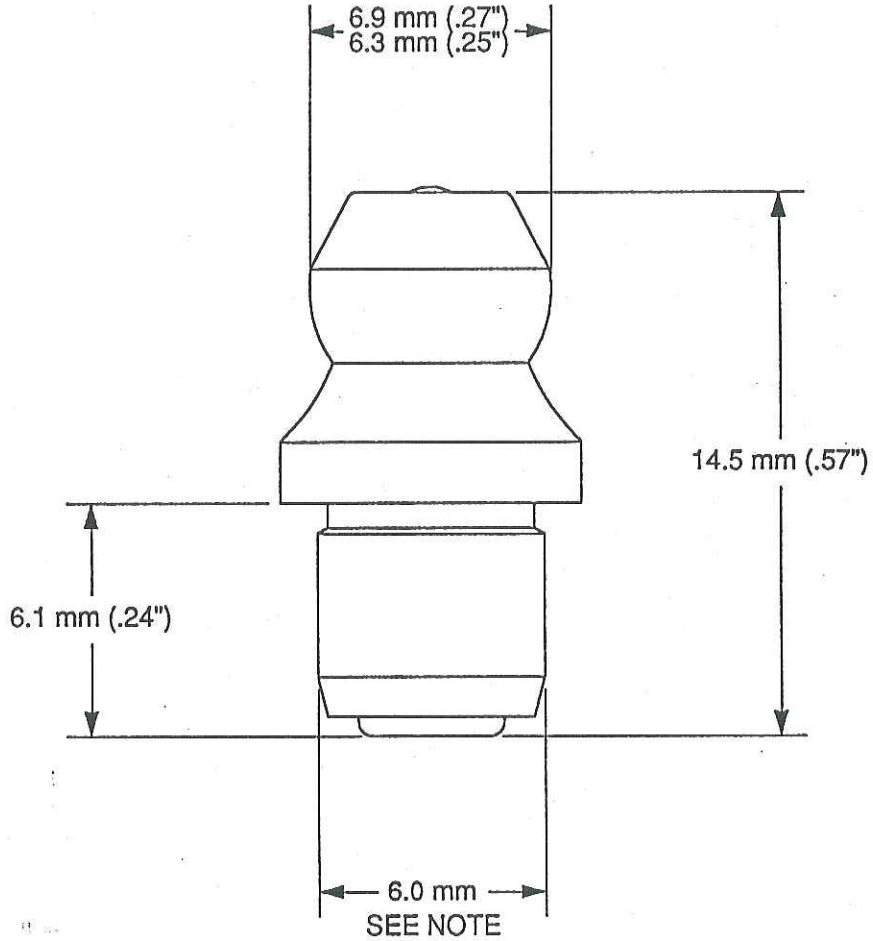

ACTUAL SIZE

SUITABLE FOR A 6mm NOMINAL HOLE SIZE.
THIS IS FOR GUIDANCE ONLY.
ACTUAL SIZE MUST BE DETERMINED BY TEST DRILLING

DESCRIPTION: 6mm DRIVE FIT
STRAIGHT HYDRAULIC GREASE FITTING

AMERICAN LUB. CODE No. **T7615**

MATERIAL:
6mm (5/16") DIA. ROUND
230 M07 Pb MILD STEEL

HEAT TREATMENT:
CARBO-NITRIDED
CASE HARDENED

PLATING:
ZINC,
YELLOW CHROMATED

TOLERANCES:
SHANK LENGTH: $\pm 0.8\text{mm}$ (.03")
OTHER: $\pm 1.0\text{mm}$ (.04") UNLESS STATED

CAD
DRAWING SCALE 5:1

COMPILER & DATE:
R.H.
14.04.93

CHECKED BY & DATE:
A.B.
19.04.93

ISSUE DATE:
22 APR 1993