

AMERICAN

LUBRICATION EQUIPMENT CORPORATION

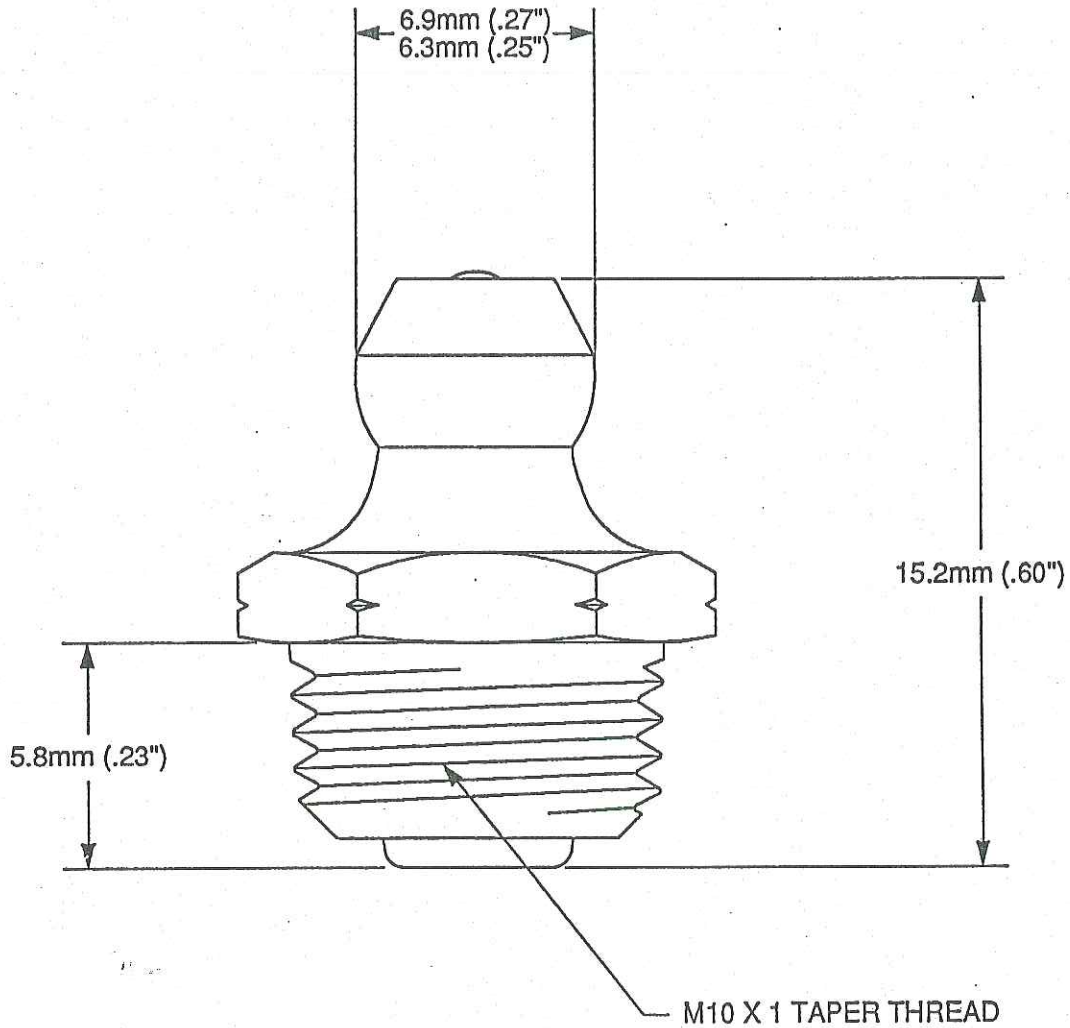

ACTUAL SIZE

DESCRIPTION: M10 X 1 TAPER, STAINLESS STEEL STRAIGHT HYDRAULIC GREASE FITTING		AMERICAN LUB. CODE No. T7806	
MATERIAL: BODY- 11mm(7/16") A/F HEX. AUSTENITIC 303 STAINLESS STEEL BALL- MARTENSITIC 440 STAINLESS STEEL SPRING- AUSTENITIC 302 STAINLESS STEEL			
HEAT TREATMENT: N/A	SURFACE TREATMENT: N/A	TOLERANCES: SHANK LENGTH: ±0.8mm (.03") OTHER: ±1.0mm (.04") UNLESS STATED	
CAD DRAWING SCALE 5:1	COMPILER & DATE: R.H. 27.10.92	CHECKED BY & DATE: A.B. 19.04.93	ISSUE DATE: 22. APR. 1993