

AMERICAN

LUBRICATION EQUIPMENT CORPORATION

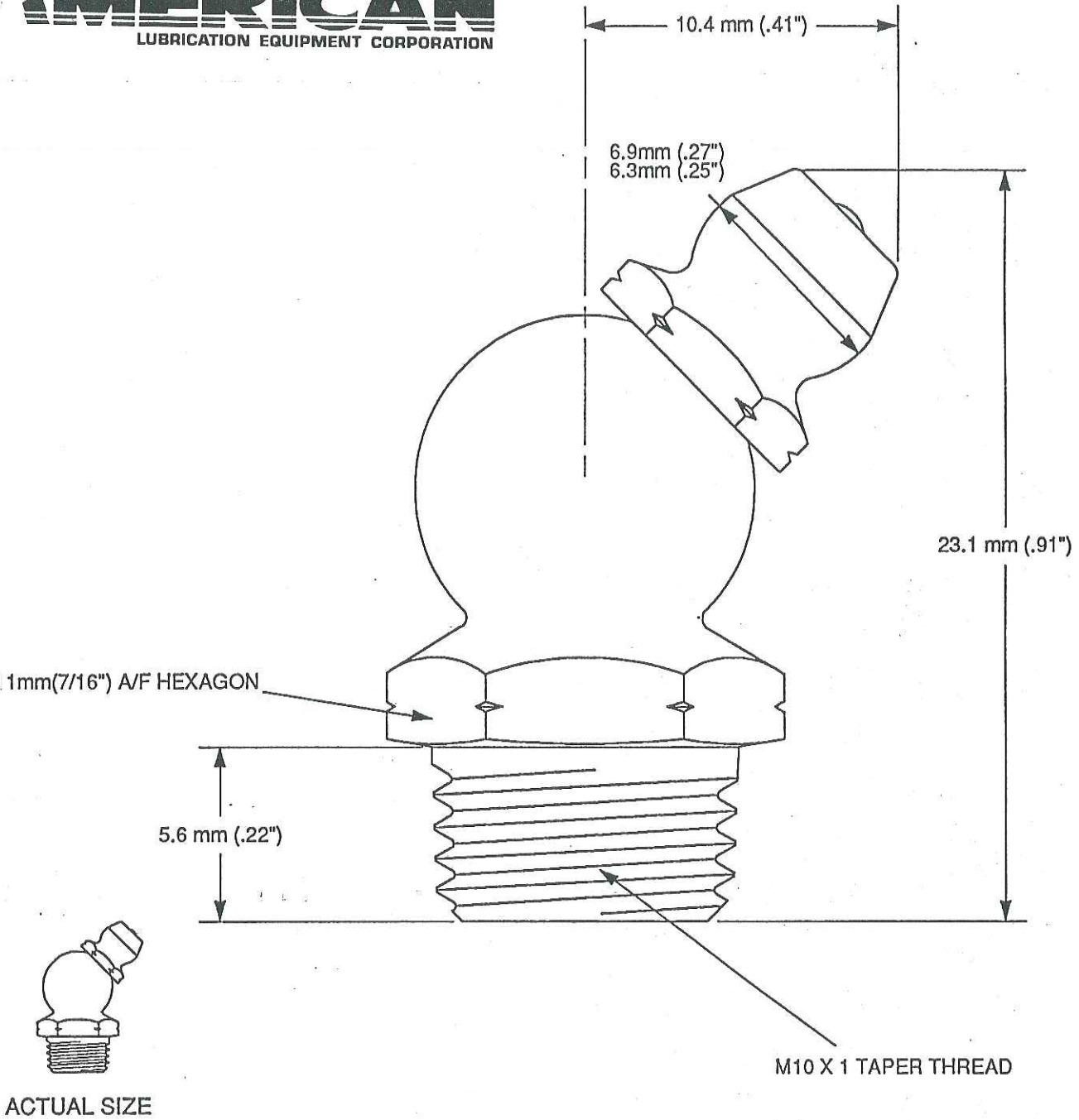

DESCRIPTION: M10 X 1 TAPER, STAINLESS STEEL
45° ANGLE HYDRAULIC GREASE FITTING

AMERICAN LUB. CODE No. **T7811**

MATERIAL: BODY & HEAD - AUSTENITIC 303 STAINLESS STEEL BALL - MARTENSITIC 440 STAINLESS STEEL
SPRING - AUSTENITIC 302 STAINLESS STEEL

HEAT TREATMENT:

N/A

PLATING:

N/A

TOLERANCES:

SHANK LENGTH: $\pm 0.8\text{mm}$ (.03")
OTHER: $\pm 1.0\text{mm}$ (.04") UNLESS STATED

CAD DRAWING SCALE 5:1

COMPILER & DATE:
R.H.
14.04.93

CHECKED BY & DATE:
A.B.
20.04.93

ISSUE DATE:
22 APR 1993