AMERICAN

LUBRICATION EQUIPMENT CORPORATION®

AMERICAN LUBRICATION EQUIPMENT CORPORATION
11212A MCCORMICK ROAD, HUNT VALLEY, MD 21031
WWW.AMERICANLUBE.COM
CONTACT: 410-252-9300

TIM-3600 SERIES ADVANTAGE PLUS HOSE REEL MANUAL



Low Pressure
Red Hose



Medium & High Pressure
Black Hose

Superior Technology at an Affordable Price®



WARNING

Read carefully and understand all INSTRUCTIONS before operating. Failure to follow the safety rules and other basic safety precautions may result in serious personal injury. Save these instructions in a safe place and on hand so that they can be read when required. Keep these instructions to assist in future servicing.



SAFETY PRECAUTIONS

GENERAL SAFETY RULES

WARNING: Read and understand all instructions.

WARNING: The warnings, cautions, and instructions discussed in this instruction manual cannot cover all possible conditions or situations that could occur. It must be understood by the operator that common sense and caution are factors which cannot be built into this product, but must be supplied by the operator.

HOSE REEL SAFETY PRECAUTIONS

- Make sure incoming line pressure does not exceed rated operating pressure for your model hose reel.
- Use proper eye protection when assembling and using the hose reel.
- Assemble the hose reel on a clean workbench.



WARNING

- Exposure of skin directly to pressurized air or fluid could result in severe bodily injury.

PRODUCT DATA

- Maximum pressure for Air/Water reels 300 PSI
- Maximum pressure for Oil/ATF/Antifreeze reels 2,320 PSI
- Maximum pressure for Grease reels 4,785 PSI

INSTALLATION

1. For overhead ceiling mounting: Install reels a maximum of 14 feet above the floor.
2. You will need to purchase fasteners for mounting your new reel. Make sure the fasteners are strong enough for the application. It is imperative to use a 3/8" (Grade 5) nut, bolt, flat washer and lock washer.
3. The reel base has four holes for mounting on a suitable flat surface. This reel features our easy slide-in base which can be used with our special mounting bracket (order separately). When using this feature please refer to the instructions which are packed in the mounting bracket.
4. The reel is supplied with a hose guide roller bracket. The bracket position may be changed depending on the reel mounting position. Figure 1 shows "Typical Mounting Positions". If bracket position needs to be changed, do the following:
 5. Pull out some hose and latch the reel.
 6. Remove the bolts that attach the guide roller bracket to the support post.
 7. Rotate guide roller bracket to correct position, replace bolts and tighten.
8. Using the four holes in the base, mount the reel in the desired location. Be sure to use appropriate hardware and tighten securely.
9. Apply Teflon tape (for oil/grease reels, add petroleum compatible pipe dope to tape) to supply line threads, attach to reel inlet and tighten. The other end of the incoming line can now be connected to the supply line.

10. Apply Teflon tape to outlet fitting on reel hose, then attach to desired tool or nozzle. Check connection for leakage, also check hose reel for correct operation. (Details see Operation section.)
11. If hose stop adjustment is required, pull hose from reel and latch the reel at desired length. Loosen hose stop bolts and slide hose stop to a position close to the hose guide. Tighten stop bolts and unlatch the reel.

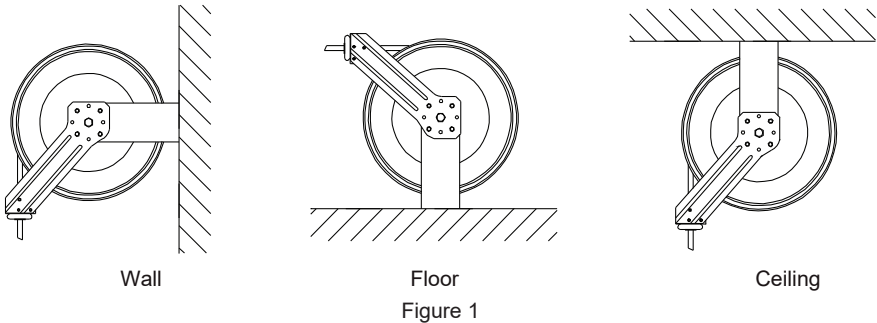

OPERATION

1. Check the reel by slowly pulling out the hose. A “clicking” noise will be heard every half revolution of the drum.
2. To latch the reel, pull out the hose and allow it to retract after hearing the first, second or third “click”.
3. To unlatch, slowly pull out the hose until the “clicking” noise stops, then let the hose retract until the hose stop rests against the hose guide.

⚠ NOTE: To avoid damage to the reel, always hold on to the hose while it is rewinding.

4. Periodically check the hose condition for wear or damage, and check the swivel fitting for leakage. Replace any worn, damaged or leaking parts.

Adjustment of Spring Tension

1. Pull out approximately 6ft of hose and allow the drum to latch.
2. Remove hose stop from hose and feed hose back through guide.
3. Wrap the pulled hose one time around the drum to increase tension or un-wrap hose one time from drum to decrease tension.
4. Re-insert hose through guide and install stop onto hose end.
5. Unlatch the drum and check tension. Pull hose from reel and adjust stop position if necessary.

Replacement of Swivel Seal

⚠ CAUTION: Bleed the line pressure from the supply line before working on the reel.

1. Disconnect supply line from swivel inlet.
2. Remove swivel assembly from reel axle.
3. Remove circle clip from swivel and take apart. Note: You may want to remove swivel from reel hose end, but this is not necessary unless a new swivel is being installed.
4. Replace the seals and reassemble swivel.
5. Use Teflon tape on swivel thread fitting, reconnect the swivel thread fitting with axle.
6. Re-connect inlet supply line.

Replacement of Hose

 **CAUTION:** Bleed the line pressure from the supply line before working on the reel. Pull out all the old hose and lock the reel.

 **CAUTION:** Make sure the reel drum is securely locked and cannot retract. Remove the two hose clamps from the hose.

 **CAUTION:** Carefully disconnect the hose from the swivel joint on the side of the reel, or the male fitting in the axle center and remove the old hose.

Feed the new hose through the guide and the opening in the reel drum and connect to the swivel. Re-install the two hose clamps, on the inside and the outside of the drum flange. Install the hose stop on the other end of the hose in the same position as before.

 **CAUTION:** Carefully release the drum latch and slowly allow the hose to wind onto the reel.

 **NOTE:** Final spring adjustment is accomplished by adding or removing wraps of hose around the drum. (Details see Adjustment of Spring Tension).

SPRING CANISTER WARNING

 **WARNING:** If the rewind spring fails the manufacturer strongly recommends the replacement of the spring canister by a factory approved service center. Do not open the spring canister for any reason. This can cause serious injury and death.

EXPLODED PARTS DIAGRAM

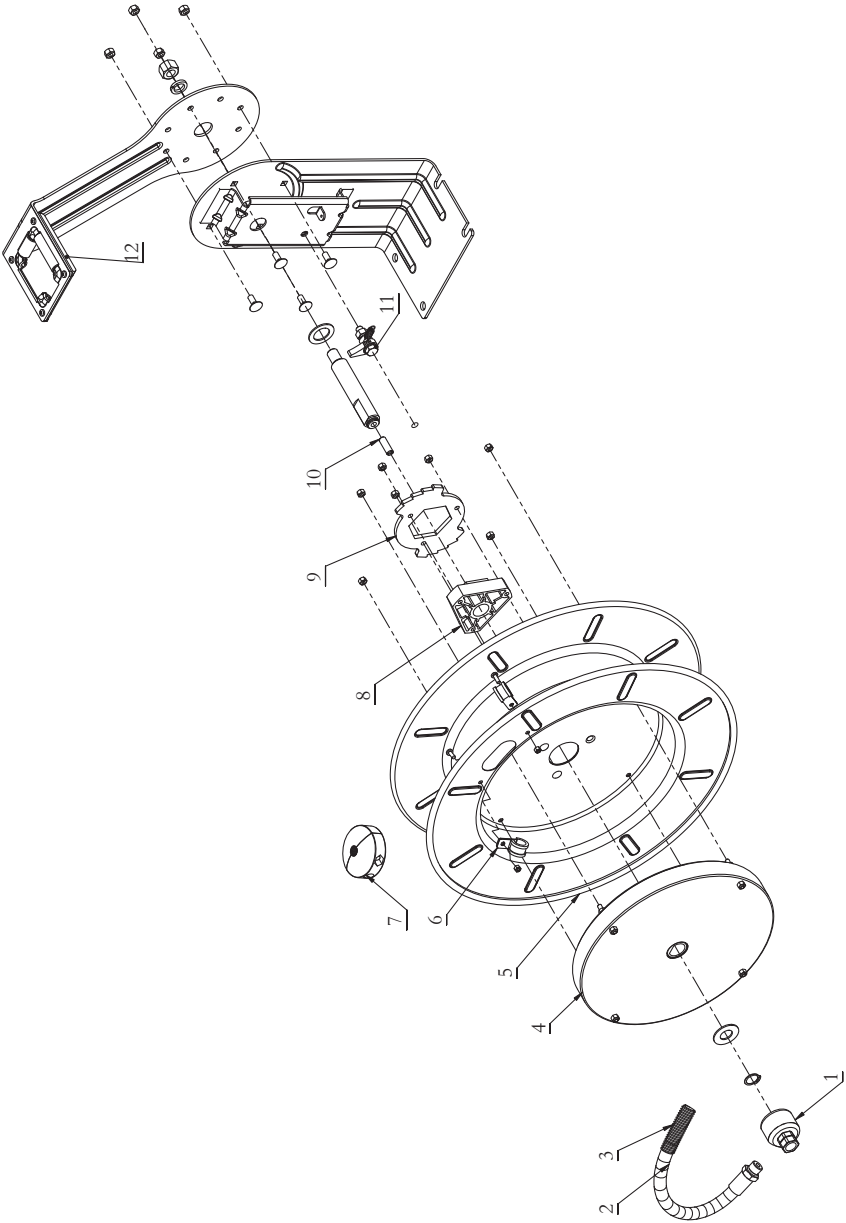

PARTS LIST

No.	Qty.	Description	Part Number	
1	1	Swivel Assembly	Reel	Swivel Assembly, order:
			TIM-3616-xx	TIM-3600-32
			TIM-3618-xx	TIM-3600-34 NOTE: Swivel seal kit, TIM-OILSWIV-KIT
			TIM-3628-xx	TIM-3600-34 NOTE: Swivel seal kit, TIM-OILSWIV-KIT
			TIM-3636-xx	TIM-3600-36
2	1	Hose, Delivery	Reel	Delivery Hose, order:
			TIM-3616-50	AIR-HP3838-50
			TIM-3616-50A	TIM-4216-50A
			TIM-3616-65	AIR-HP3838-65
			TIM-3616-65A	TIM-4216-65F
			TIM-3618-50	TIM-4208-50F
			TIM-3618-65	TIM-4208-65F
			TIM-3628-25	TIM-4418-25S
			TIM-3628-50	TIM-4418-50S
			TIM-3628-65	TIM-4418-65S
			TIM-3636-50	TIM-4506-50S
TIM-3636-65	TIM-4506-65S			
3	1	Hose Guard	TIM-238-1	
4	1	Rewind Spring Assembly	Reel	Rewind Spring Assembly, order:
			TIM-3616-50, TIM-3616-50A	TIM-3600-23
			TIM-3616-65, TIM-3616-65A	TIM-3600-24
			TIM-3618-50, TIM-3618-65	TIM-3600-26
			TIM-3628-50	TIM-3600-27
			TIM-3636-50	TIM-3600-30
			TIM-3636-65	TIM-3600-31
5	1	Drum Assembly	BLK-REEL-HUB	
6	2	Hose Clamp	TIM-HOSE-CLMP	
7	1	Hose Stop Assembly	TIM-131-3 for 3/8" Air/Grease hose	
			TIM-131-4 for 1/2" Air/Oil hose	
8	1	Hub Bearing	TIM-3600-17	
9	1	Locking Ring	TIM-3600-16	
10	1	Axle Stud	No part number (M10 x 1.5 x 30mm)	
11	1	Ratchet Assembly	TIM-3600-14 Note: Latch spring is included in the Ratchet Assembly but is also sold individually, order: TIM-3600-22	
12	1	Side Arm and Roller Assembly	TIM-3600-2 Side Arm	
			TIM-3600-3 Metal guide plate for Roller Assembly	
			TIM-3600-4 Roller Assembly includes rollers and pins. Guide plate not included	

TIM-3600-14 Ratchet Assembly Replacement Procedure

1. Remove fluid pressure.
2. Pull 3' of hose out of reel.
3. Remove control handle, hose stop, etc.
4. Relieve all recoil spring tension by slowly retracting the hose into the reel.
5. Remove swivel retaining ring and spacer.
6. Slide drum off axle.
7. Replace old parts with new TIM-3600-14 kit parts (cam, spring, bolt, etc.).
8. Reassemble.
9. Tension reel by turning the drum three complete turns.
10. Latch drum.
11. Reassemble hose stop, etc.

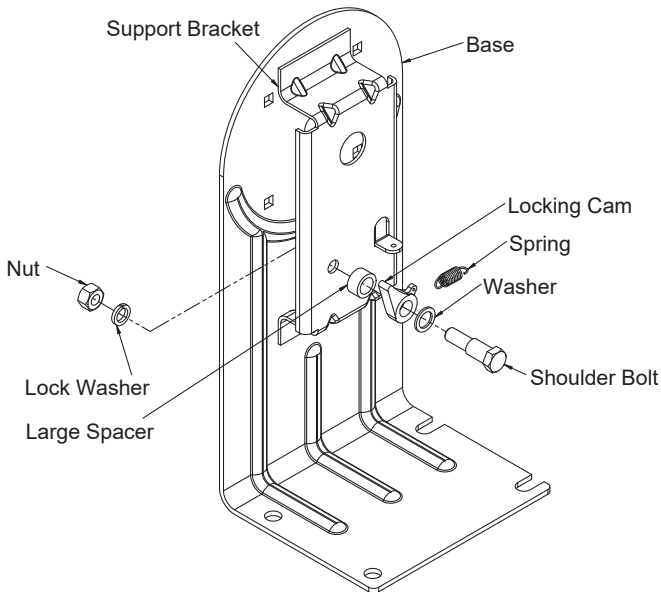

If the hose is lying on the floor and won't retract at all, the one foot in diameter, rewind spring canister is broken.

If the hose is mechanically stuck, won't pull out, won't retract, the latch assembly is jammed.

If the hose pulls out and retracts, but does not lock, the latch spring (aka, stop dog spring; weighs 0.1 ounces, 1/2" long, 1/4" diameter) is broken.

If the hose retracts but won't retract the whole way back into the reel, there are several different possibilities,

- a. Verify that the axle nut is torqued to 100 ft./lbs. If the nut was loose, torque and then add one or two hose wraps. Test.
- b. Add one or two additional hose wraps which increases the rewind spring canister's hose retract tension. Test.
- c. Remove hose hub assembly, clean and grease axle and bushing. Test.
- d. Replace rewind spring. Test.

Mounting Hole Dimensions

L = 5-63/64"; M = 3-15/16"

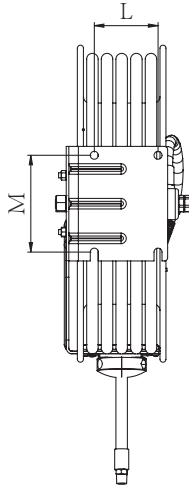

Size Index Chart

A	B	C	D	E	Mount L-M
8-7/16"	21-1/2"	20-5/8"	6-3/32"	7-3/32"	5-63/64" x 3-15/16"

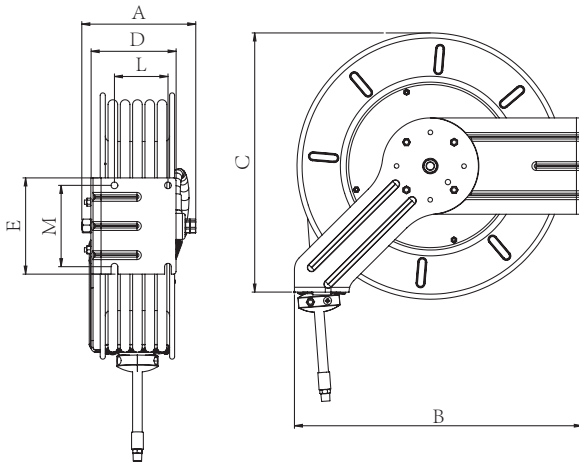

14' maximum mounting height