

Note: Valve assembly is *not* sealed and should not be considered for gasoline.

FMMASO-91S Overfill Warning Valve Installation & Maintenance Instructions

The FMMASO-91S Overfill Warning Valve (OWV) is used to shut off the air supply to the pump when the tank approaches full capacity. When the OWV shuts off air to the pump, air is diverted to a whistle mounted on the unit to signal an alert that the tank is full. The OWV is automatically reset when the tank is emptied and air pressure in the OWV is zero.

Specifications

| | |
|-----------------------------|--------------------|
| Air Inlet | 1/4" Female N.P.T. |
| Air Outlet | 1/4" Female N.P.T. |
| Signal Port | 1/8" Female N.P.T. |
| Mounting | 2" Male N.P.T. |
| Maximum Air Pressure | 100 PSI |
| Air Flow Capacity | 20 CFM @ 100 PSI |
| Operating Temperature | -10° to 185° F |
| Weight | 2 lbs |

General Requirements

The following safety precautions need to be observed before operating the unit:

1. DO NOT exceed the pressure rating of any component in the system.
2. Read all instruction sheets, and any other explanatory material before attempting to operate, assemble, or disassemble the system.
3. Protect all material and air supply lines from puncture or damage. Especially be aware of places where lines or hoses may be damaged when flexing or twisting, or by hot machinery or moving parts.
4. All lines should be inspected daily for weak or worn condition prior to work operations.
5. Disconnect air and material supply lines and relieve pressure prior to removing or servicing any component in the system.

Caution: The Overfill Warning Valve is not intended to reduce or replace user responsibility when transferring liquids to a tank.

Attention: La soupape d'avertissement de remplissage excessif n'est pas conçue afin de diminuer ou de remplacer la responsabilité de l'utilisateur lors du transfert de liquide dans un réservoir.

When the OWV alarm is sounded, the pump transferring liquid to the tank must be turned off immediately to prevent possible overfill of tank.

Installation

Note: Reduce air pressure in airline to zero prior to connecting the Overfill Warning Valve.

1. Check tank for obstructions that could block the movement of the float.

Note: Install the OWV in a manner that will allow the float to move freely.

2. Back off set screw in threaded collar enough that the collar will rotate freely around OWV body (Diagram 1).
3. Insert OWV assembly into bung opening at the top of the tank.

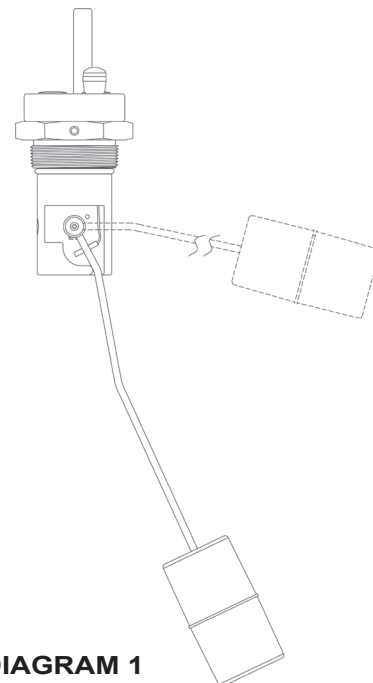

The float indicator “ARROW” on the top of OWV must point to the area selected for float operation (Diagram 2).

4. Hold top of the OWV in position while screwing OWV collar into tank.
5. Ensure that the float indicator “ARROW” is in desired operating position before tightening collar set screw. The OWV is in operating position when the set screw is tightened.
6. Connect air supply to the “IN” port and connect the pump’s air inlet to the “OUT” port on the OWV.

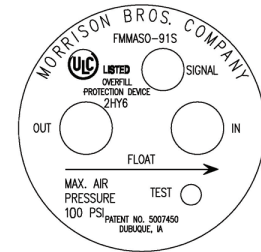

DIAGRAM 2

Note: The air filter/moisture separator, regulator, oiler, if used should be placed in the air line before the Overfill Warning Valve (Diagram 3).

Note: If an oiler is used, hydraulic oil or 10 weight motor oil should be used in it. Antifreeze can be used whenever the combination of extreme cold weather and wet air are present.

Maintenance

Note: The Overfill Warning Valve is similar to a fine air tool and its life and performance can be drastically reduced by air that has not been filtered to remove moisture and particle contamination.

1. The Overfill Warning Valve should be tested several times a year. The test is performed by lifting the test button about one inch. This should cut off air to the pump and sound the signal whistle. When the button is released, the OWV should reset. If it does not reset, relieve air pressure in valve. This will allow the OWV to reset.

CAUTION: All worn or damaged parts are a threat to personnel and property and need to be replaced.

ATTENTION: Toutes les pièces usées ou endommagées représentent une menace pour le personnel et les biens détenus en propriété, et doivent être remplacées.

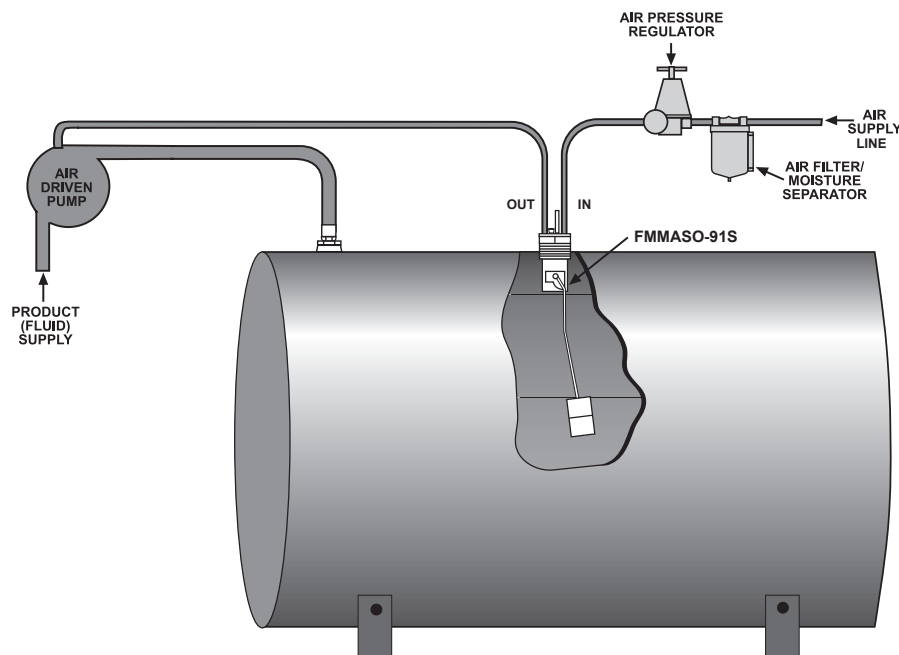

DIAGRAM 3